



04_CATALOGO
CATALOGUE

VIGANÓ
OFFICE CHAIRS AND MORE

In Brianza, cuore pulsante del design industriale italiano, dal 1961, Viganò & C. produce elementi d'arredo per l'ufficio ed il contract. "Il nostro obiettivo è la soddisfazione del cliente, per il quale sviluppiamo arredi dal design essenziale, in cui il comfort e l'attenzione per il dettaglio sono imprescindibili".

Una progettazione spesso tailor-made, allieva della più alta tradizione del manifatturiero industriale italiano, dove la ricerca minuziosa dei materiali e delle più avanzate tecnologie donano al fruitore un'esperienza di seduta a tutto tondo.

Prodotti realizzati con attenzione sartoriale grazie ad un corretto bilanciamento estetico ed ergonomico.

Prodotti che rispondono alle più severe normative internazionali senza scendere a compromessi. Oggetti che accompagnano i momenti fondamentali della nostra vita.

Since 1961, Viganò & C. has been producing furniture for the office and contract sector, in Brianza, the beating heart of Italian industrial design. "Customer satisfaction is our aim, that's why we create products distinguished by timeless design where comfort and passion for detail are essential".

A design often tailor-made, originating from the highest tradition of Italian industrial manufacturing, where the meticulous research of materials and the most advanced technologies provide an all-round sitting experience to the user.

Products realized with sartorial attention thanks to a state of the art balance between aesthetic and ergonomics.

Products that meet the most stringent international standards without compromising. Objects that accompany the greatest moments of our life.



VIGANÒ
OFFICE CHAIRS AND MORE

**“Pensiamo,
progettiamo,
prototipiamo,
ingegnerizziamo e
industrializziamo...
per proporvi oggetti
dal design unico ed
irripetibile”**

*“We think,
we design,
we prototype,
we engineer and
we industrialize...
to propose unique and
unrepeatable design objects”*





Indice/ *Index*



015

Maggy

Imbottiti
Padded



025

Maggy big

Imbottiti
Padded

031

Milly

Imbottiti
Padded



041

Milly big

Imbottiti
Padded



047

Miss Grace

Imbottiti
Padded



055

Syrio

Imbottiti
Padded

061

Greg

Imbottiti
Padded



069

George

Imbottiti
Padded



113

Adele

Sedute
Armchairs



125

Winner

Sedute
Armchairs



079

Cubino

Imbottiti
Padded



085

Cubiko

Imbottiti
Padded



137

Omega

Sedute
Armchairs



145

**Madam
Office**

Sedute
Armchairs

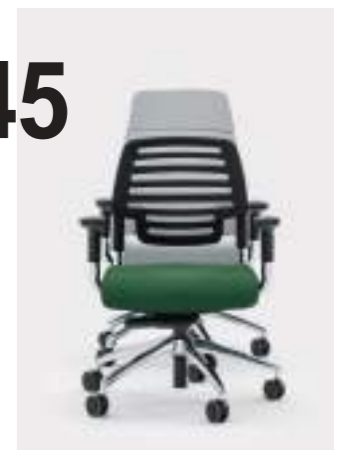

093

Tommy

Imbottiti
Padded



101

Jolie

Sedute
Armchairs



153

Charme

Sedute
Armchairs



159

Grace

Sedute
Armchairs



167

Queen
2022

Sedute
Armchairs



181

Queen
mesh

Sedute
Armchairs

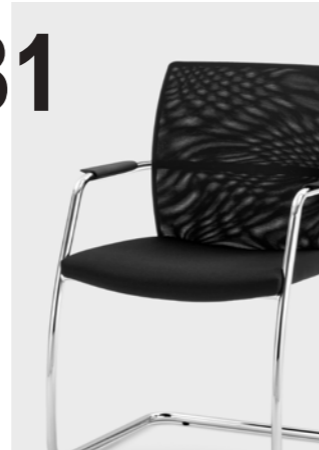

215

Ozium

Sedute
Armchairs



219

Beo

Sedute
Armchairs



185

Star

Sedute
Armchairs



191

Logika

Sedute
Armchairs

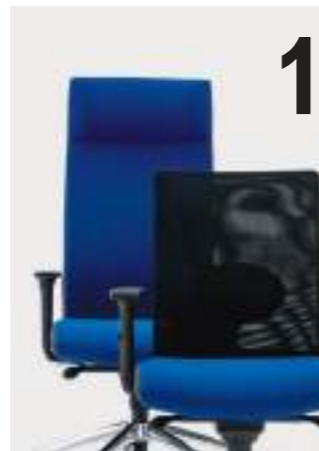

223

Mary

Sedute
Chairs



229

Kate

Sedute
Chairs



199

Time

Sedute
Armchairs



207

Celo

Sedute
Armchairs

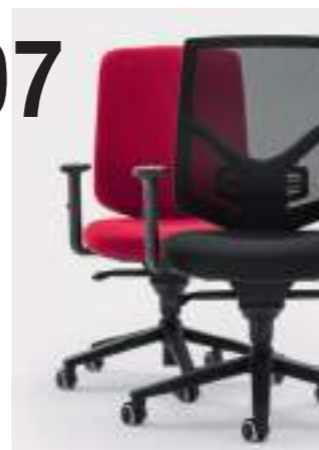

235

Madam
collettività

Sedute
Chairs



241

Ken

Sedute
Armchairs



249

Daisy

Sedute
Chairs



259

Daisy metal

Sedute
Chairs



287

Fred

Tavoli
Tables



293

Arturo

Tavoli
Tables



265

**Ted
Ted up**

Sgabelli
Stools



271

Joe

Sgabelli
Stools



299

Jack

Tavoli bar
Bar tables



303

Ginger

Tavoli bar
Bar tables

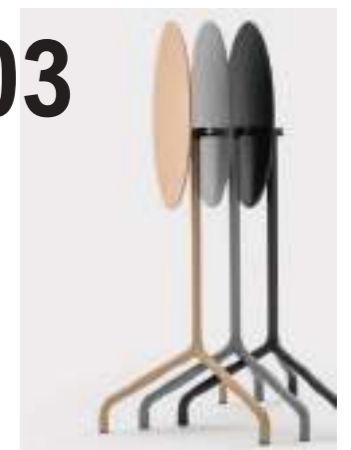

279

Shake

Sgabelli
Stools



283

Ermes

Tavoli
Tables



309

Felix

Tavoli bar
Bar tables



313

Apollo

Tavolini
Service tables



317

Stilo

Accessori
Accessories



LEGENDA Legend



Outdoor
Outdoor

30

Tutte le misure sono espresse in centimetri
All dimensions are expressed in centimeters

* Le descrizioni materiche dei prodotti nelle foto vanno da sinistra a destra
* The products material descriptions in the pictures go from left to right

MAGGY

DESIGN **BASAGLIA + ROTA NODARI**

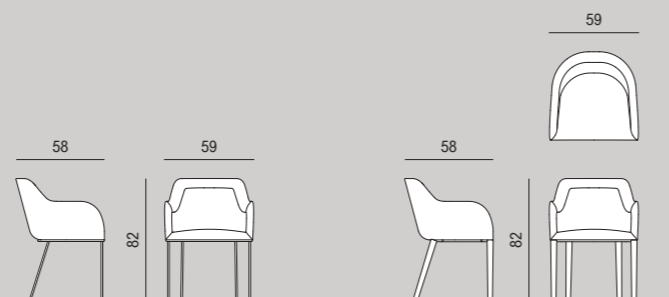

POLTRONCINA VISITATORE | VISITOR ARMCHAIR

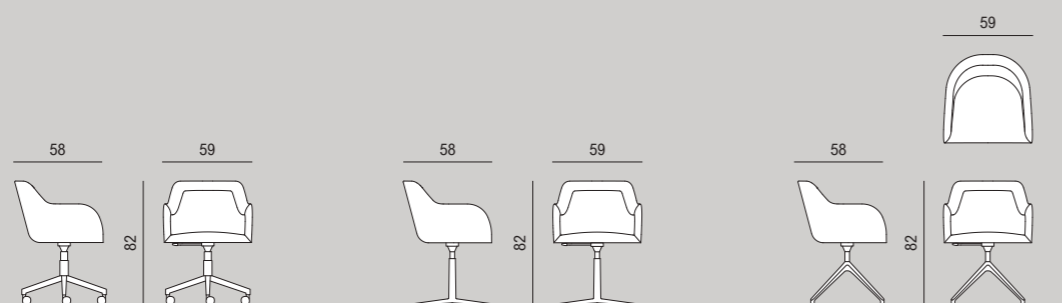

POLTRONCINA MEETING | MEETING ARMCHAIR







Poltroncina visitatore con struttura in tondino d'acciaio / tessuto Tulipano 1011 + struttura verniciata RAL6021 • 1000 + RAL1004 • 1015 + RAL9005
• 1003 + RAL3020 • 1017 + RAL7043 • 1016 + RAL7004 • 1002 + RAL2012 • 1006 + RAL9003
Visitor armchair with steel rod frame / Tulipano fabric 1011 + epoxy powder coated frame RAL6021 • 1000 + RAL1004 • 1015 + RAL9005 • 1003 +
RAL3020 • 1017 + RAL7043 • 1016 + RAL7004 • 1002 + RAL2012 • 1006 + RAL9003





MAGGY big

DESIGN BASAGLIA + ROTA NODARI

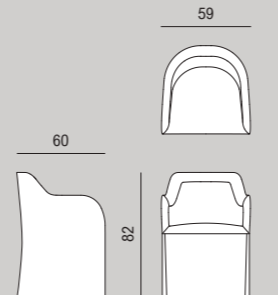

POLTRONCINA VISITATORE | VISITOR ARMCHAIR





MILLY

DESIGN **BASAGLIA + ROTA NODARI**

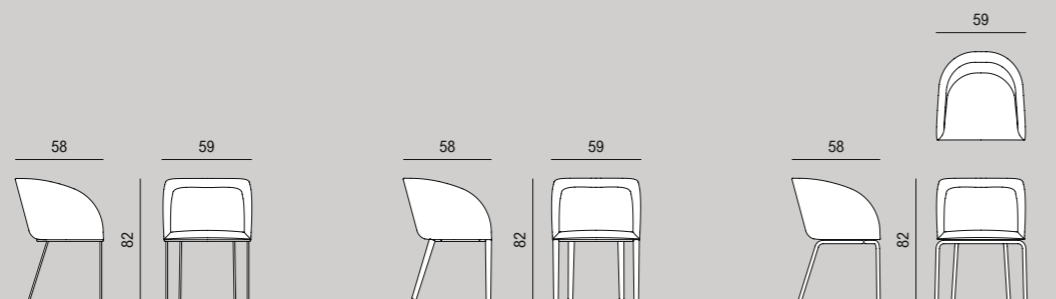

POLTRONCINA VISITATORE | VISITOR ARMCHAIR

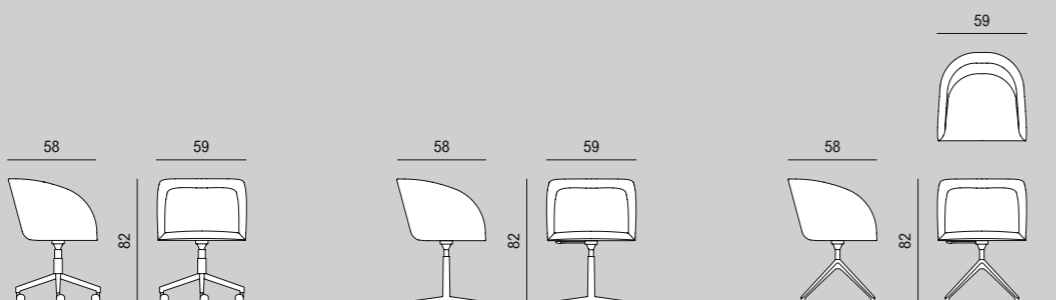

POLTRONCINA MEETING | MEETING ARMCHAIR

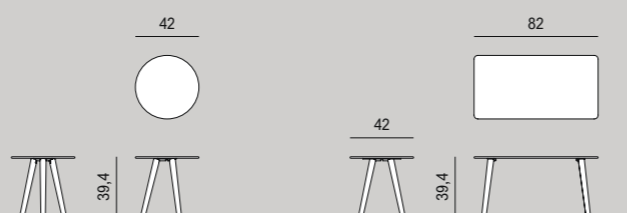

TAVOLINO | SERVICE TABLE







Poltroncina visitatore con struttura in tondino d'acciaio / tessuto Tulipano 1006 + struttura verniciata RAL9003 • 1016 + RAL7004 • 1017 + RAL7043
• 1015 + RAL9005 • 1011 + RAL6021 • 1000 + RAL1004 • 1002 + RAL2012 • 1003 + RAL3020 • 1008 + RAL1019
Visitor armchair with steel rod frame / Tulipano fabric 1006 + epoxy powder coated frame RAL9003 • 1016 + RAL7004 • 1017 + RAL7043 • 1015 +
RAL9005 • 1011 + RAL6021 • 1000 + RAL1004 • 1002 + RAL2012 • 1003 + RAL3020 • 1008 + RAL1019



Poltroncina visitatore con struttura in tubo d'acciaio / tessuto Tulipano 1015 + struttura verniciata RAL9005 • 1017 + RAL7043 • 1016 + RAL7004 • 1006 + RAL9003 • 1003 + RAL3020 • 1002 + RAL2012 • 1000 + RAL1004 • 1011 + RAL6021
Visitor armchair with steel tubular frame / Tulipano fabric 1015 + epoxy powder coated frame RAL9005 • 1017 + RAL7043 • 1016 + RAL7004 • 1006 + RAL9003 • 1003 + RAL3020 • 1002 + RAL2012 • 1000 + RAL1004 • 1011 + RAL6021

Poltroncina visitatore con struttura in tubo d'acciaio / tessuto Tulipano 1004 + struttura cromata
Visitor armchair with steel tubular frame / Tulipano fabric 1004 + chromed frame



MILLY big

DESIGN BASAGLIA + ROTA NODARI

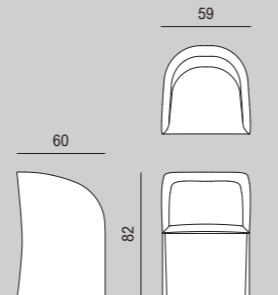

POLTRONCINA VISITATORE | VISITOR ARMCHAIR







Miss GRACE

VIGANÒ EDITOR

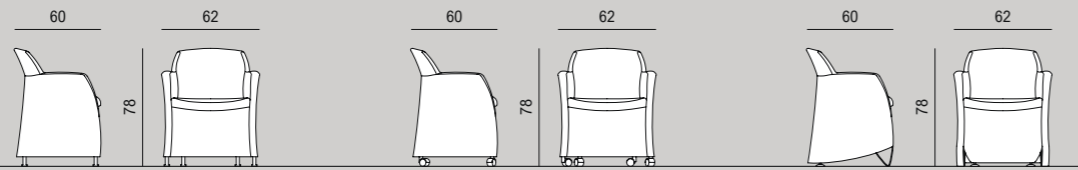

POLTRONCINA VISITATORE | VISITOR ARMCHAIR

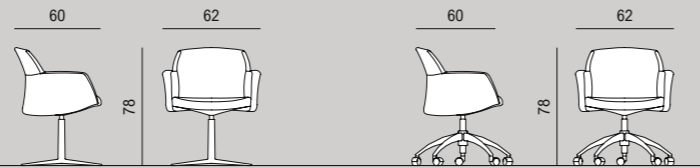

POLTRONCINA MEETING | MEETING ARMCHAIR









SYRIO

R&D VIGANÒ

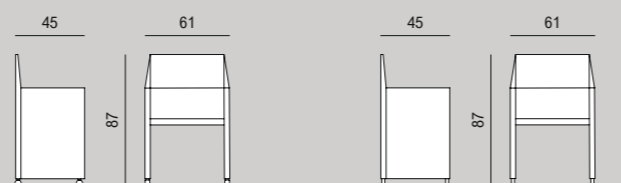

POLTRONCINA ATTESA | VISITOR ARMCHAIR

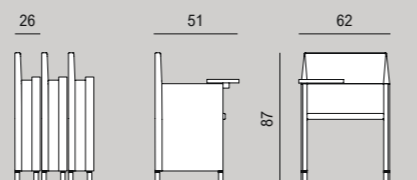

POLTRONCINA TRAINING | TRAINING ARMCHAIR







GREG

DESIGN **BASAGLIA + ROTA NODARI**

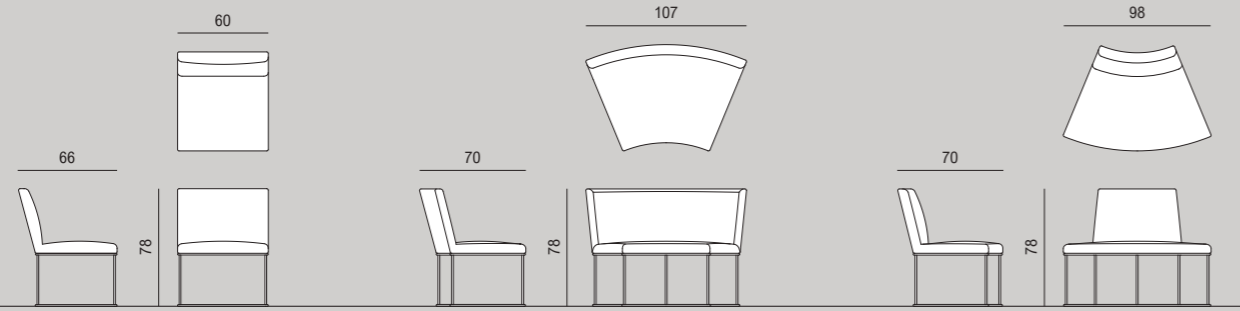

MODULO CENTRALE + MODULO CONCAVO + MODULO CONVESSO | *CENTRAL UNIT + CONCAVE UNIT + CONVEX UNIT*

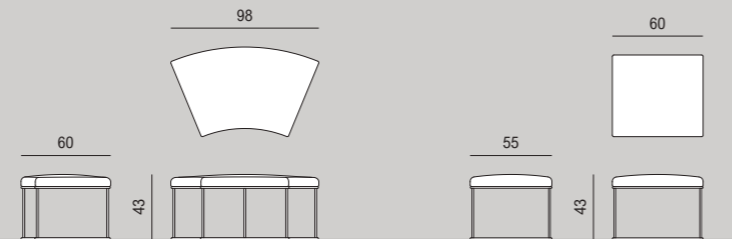

POUF | *POUF*

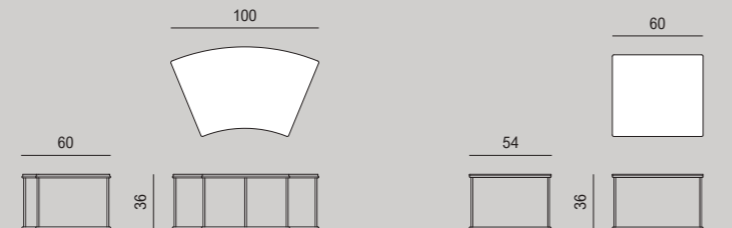

TAVOLINO | *SERVICE TABLE*

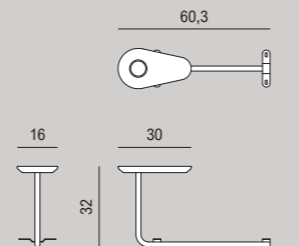

TAVOLINO CON CARICATORE | *TABLE WITH CHARGER*



Esempio di composizione 01 / tessuto Tulipano 1010, piano tavolino con caricatore in MDF laccato antracite, piano tavolino Vitter antracite, struttura verniciata RAL7043

Example of composition 01 / Tulipano fabric 1010, anthracite lacquered MDF table top with charger, anthracite Vitter service table top, epoxy powder coated frame RAL7043



Esempio di composizione 03 / tessuto Tulipano 1002, piano tavolino con caricatore in MDF laccato bianco, piano tavolino Vitter rosso, struttura verniciata RAL3020

Example of composition 03 / Tulipano fabric 1002, white lacquered MDF table top with charger, red Vitter service table top, epoxy powder coated frame RAL3020



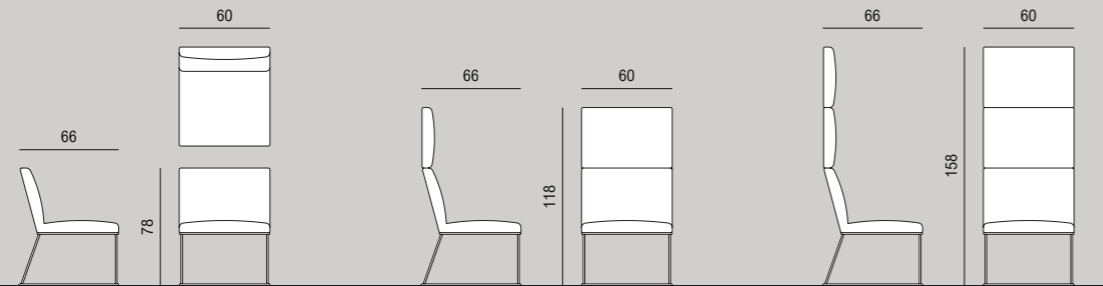

MODULO CENTRALE | *CENTRAL UNIT*

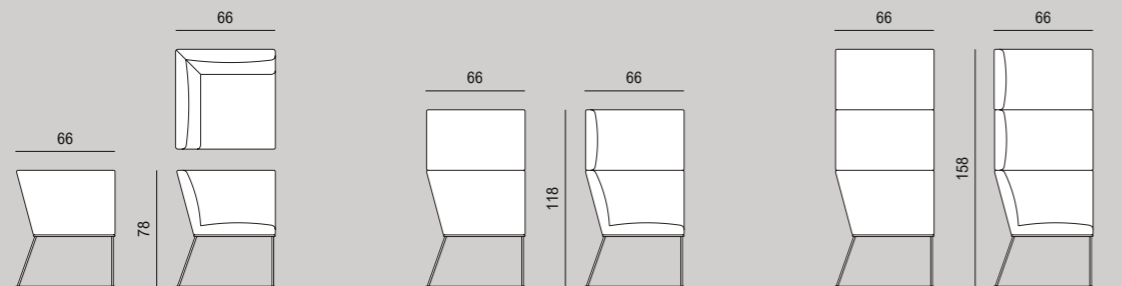

MODULO LATERALE | *CORNER UNIT*

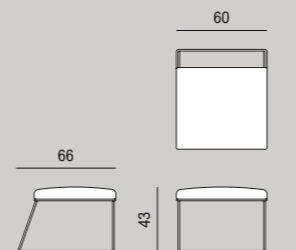

POUF | *POUF*

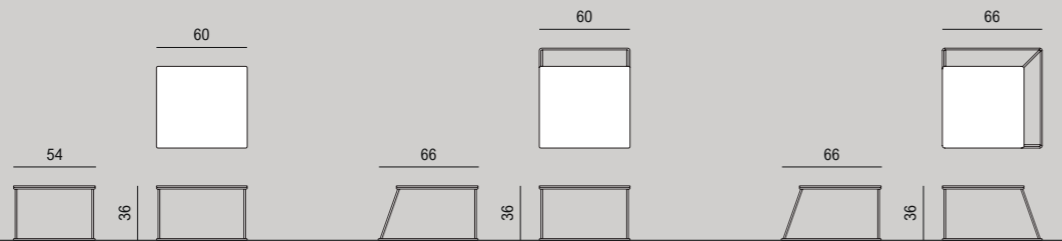

TAVOLINO | *SERVICE TABLE*

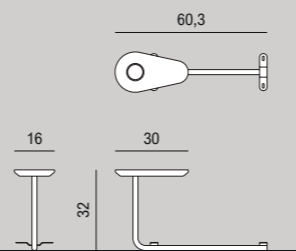

TAVOLINO CON CARICATORE | *TABLE WITH CHARGER*

GEORGE

DESIGN BASAGLIA + ROTA NODARI











CUBINO

VIGANÒ EDITOR

POLTRONA | *ARMCHAIR*

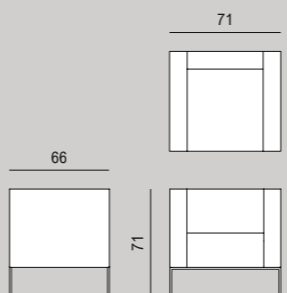

DIVANO 2 POSTI | *2-SEATER SOFA*

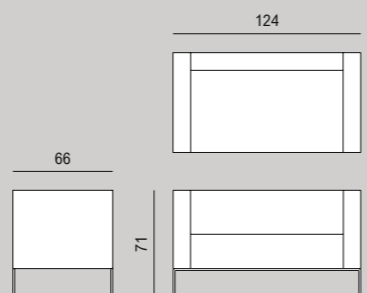

DIVANO 3 POSTI | *3-SEATER SOFA*

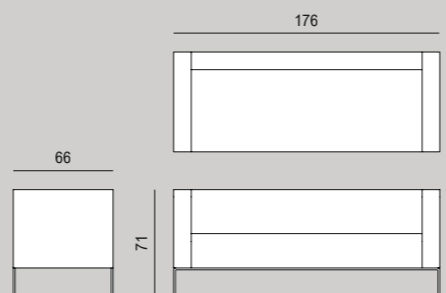

PANCA | *BENCH*

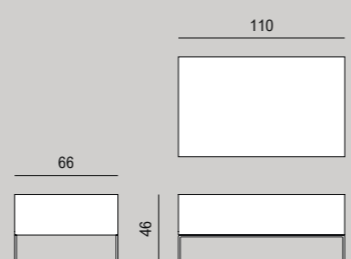





CUBIKO

VIGANÒ EDITOR

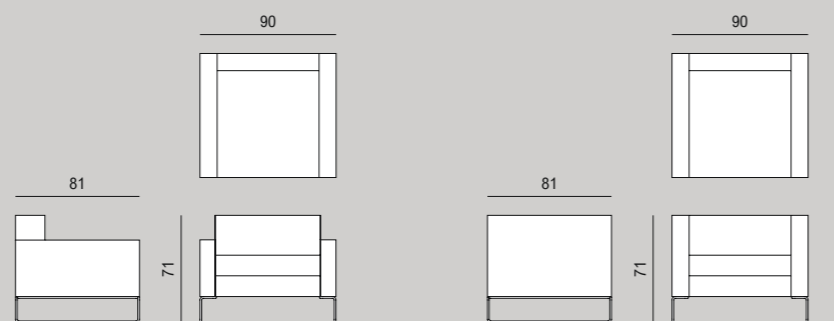

POLTRONA CON BRACCIOLI BASSI E ALTI | *ARMCHAIR WITH LOW AND HIGH ARMRESTS*

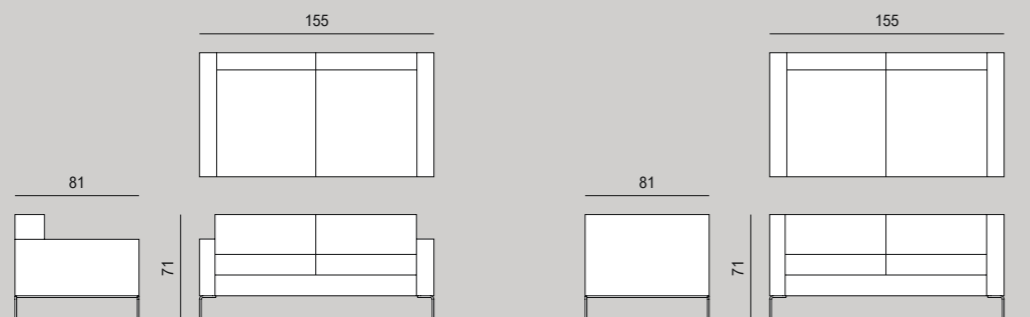

DIVANO 2 POSTI CON BRACCIOLI BASSI E ALTI | *2-SEATER SOFA WITH LOW AND HIGH ARMRESTS*

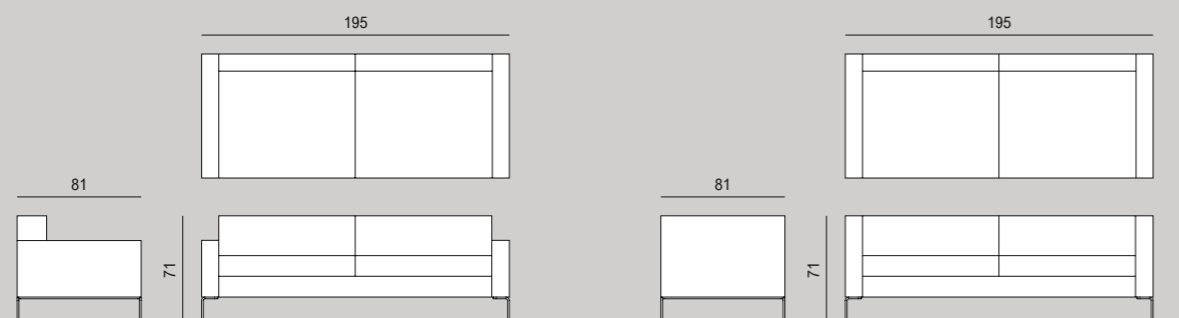

DIVANO 3 POSTI CON BRACCIOLI BASSI E ALTI | *3-SEATER SOFA WITH LOW AND HIGH ARMRESTS*



TAVOLINO | *SERVICE TABLE*









TOMMY

DESIGN BASAGLIA + ROTA NODARI

POUF MINI | *MINI POUF*

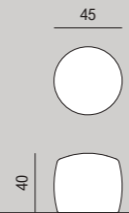

POUF PICCOLO | *SMALL POUF*

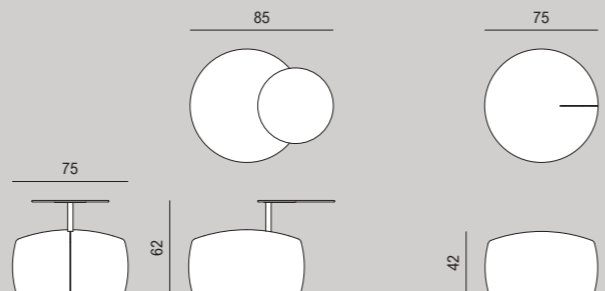

POUF MEDIO | *MEDIUM POUF*

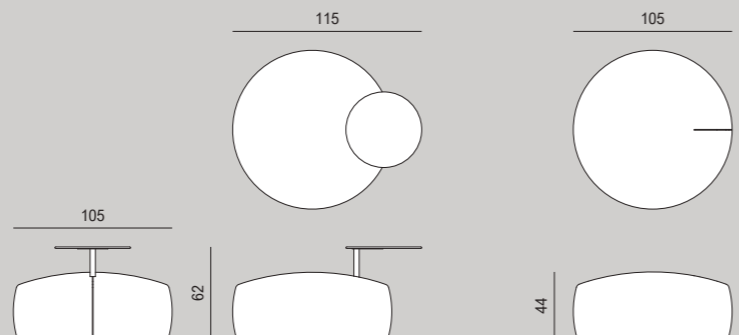

POUF GRANDE | *BIG POUF*

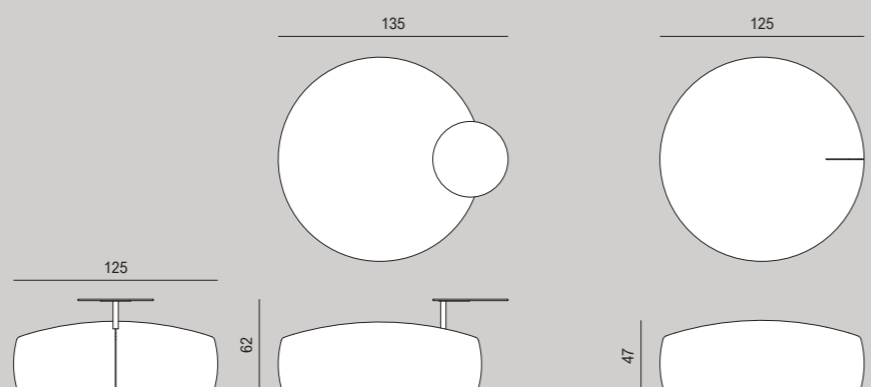

PARAVENTO + TAVOLINO CON E SENZA CARICATORE | *WINDSCREEN + WAITING TABLE WITH AND WITHOUT CHARGER*

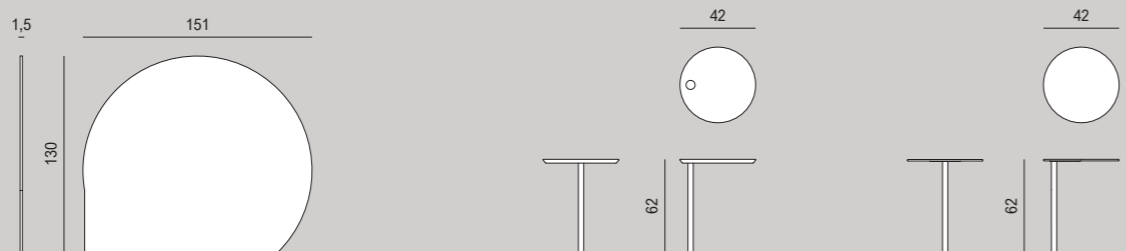





Pouf medio + pouf piccolo / tessuto Tulipano 1003 + similpelle Fiordaliso 1028 + piano tavolino Vitter rosso • Tulipano 1006 + Fiordaliso 1030 + piano tavolino Vitter bianco
Medium pouf + small pouf / Tulipano fabric 1003 + Fiordaliso simil-leather 1028 + red Vitter waiting table top • Tulipano 1006 + Fiordaliso 1030 + white Vitter waiting table top



JOLIE

DESIGN **ORLANDINIDESIGN**



SEDUTA OPERATIVA CON E SENZA BRACCIOLI | *TASK ARMCHAIR WITH AND WITHOUT ARMRESTS*













ADELE

DESIGN ORLANDINIDESIGN

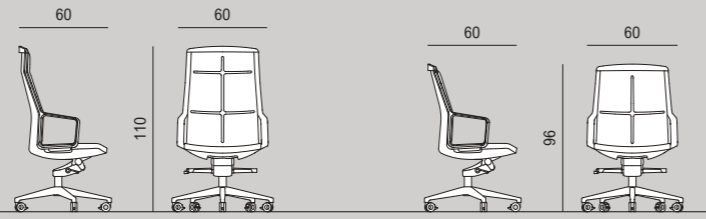

SEDUTA DIREZIONALE E SEMIDIREZIONALE IMBOTTITA | *PADDED EXECUTIVE AND MANAGER ARMCHAIR*

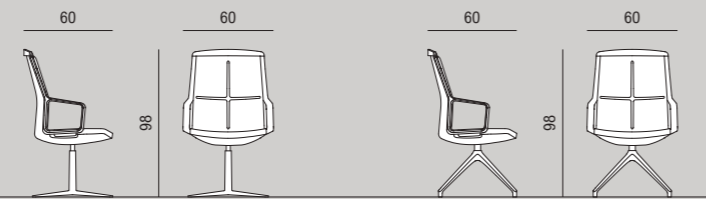

SEDUTA MEETING E VISITATORE IMBOTTITA | *PADDED MEETING AND VISITOR ARMCHAIR*

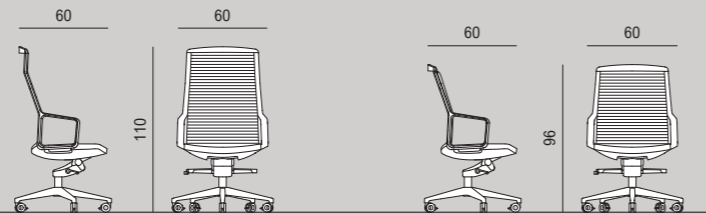

SEDUTA DIREZIONALE E SEMIDIREZIONALE IN RETE | *EXECUTIVE AND MANAGER ARMCHAIR, MESH BACKREST*

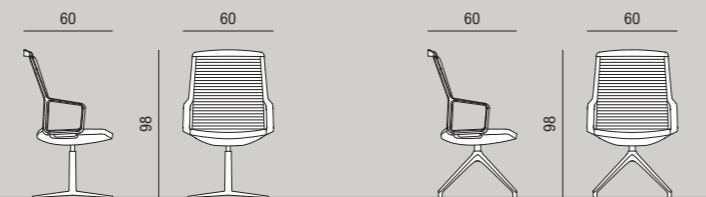

SEDUTA MEETING E VISITATORE IN RETE | *MEETING AND VISITOR ARMCHAIR, MESH BACKREST*













WINNER

VIGANÒ EDITOR

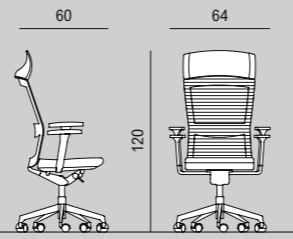

SEDUTA DIREZIONALE | EXECUTIVE ARMCHAIR

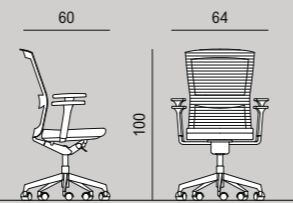

SEDUTA OPERATIVA E METTING | TASK AND MEETING ARMCHAIR

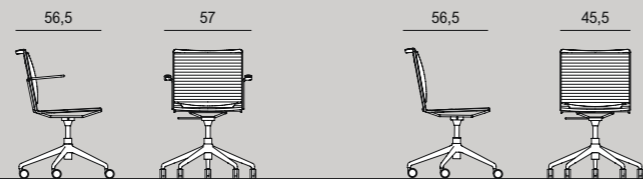

SEDUTA MEETING CON E SENZA BRACCIOLI | MEETING ARMCHAIR WITH AND WITHOUT ARMRESTS

max 15
max 350 kg

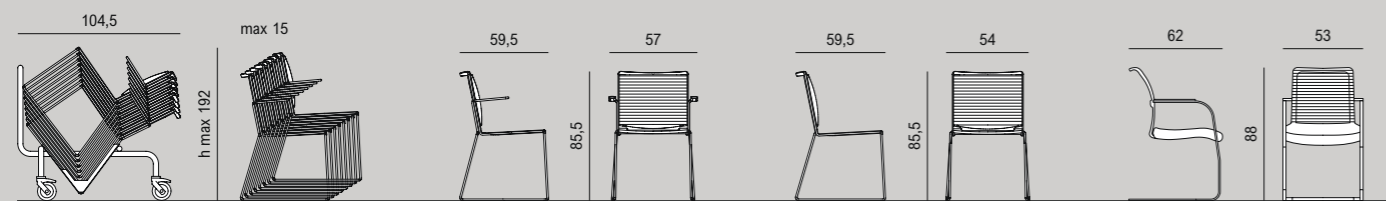

SEDUTA ATTESA CON E SENZA BRACCIOLI + VISITATORE CANTILEVER | VISITOR CHAIR WITH AND WITHOUT ARMRESTS + SKID FRAME

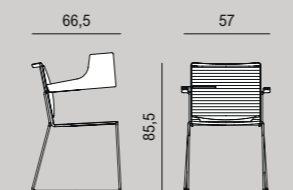

SEDUTA TRAINING | TRAINING CHAIR











OMEGA

VIGANÒ EDITOR

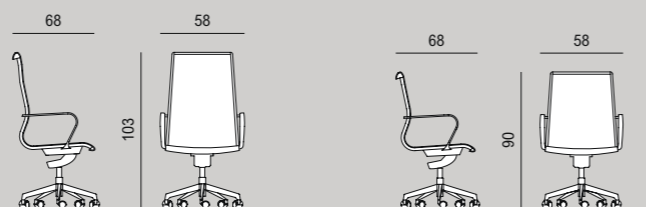

SEDUTA DIREZIONALE E SEMIDIREZIONALE IMBOTTITA | *PADDED EXECUTIVE AND MANAGER ARMCHAIR*

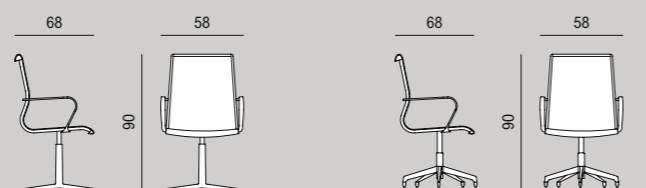

SEDUTA MEETING E VISITATORE IMBOTTITA | *PADDED MEETING AND VISITOR ARMCHAIR*

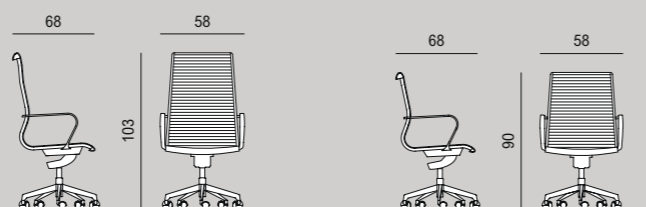

SEDUTA DIREZIONALE E SEMIDIREZIONALE IN RETE | *MESH EXECUTIVE AND MANAGER ARMCHAIR*

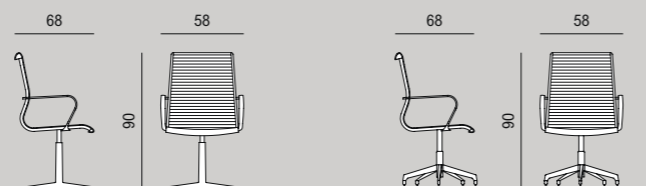

SEDUTA MEETING E VISITATORE IN RETE | *MESH MEETING AND VISITOR ARMCHAIR*









MADAM office

DESIGN ROBERTO MOLteni + IVO PELLEGRi

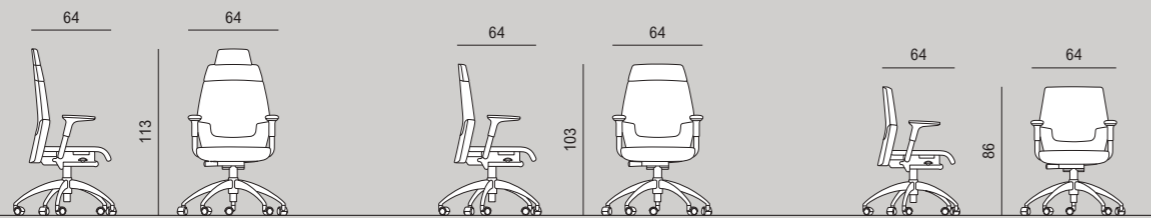

SEDUTA PRESIDENZIALE, DIREZIONALE E SEMIDIREZIONALE | *PRESIDENTIAL, EXECUTIVE AND MANAGER ARMCHAIR*

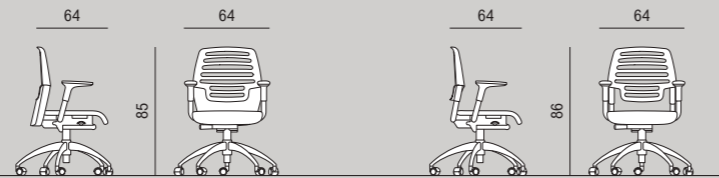

SEDUTA OPERATIVA | *TASK ARMCHAIR*







Sedute presidenziale + direzionale + semidirezionale / pelle Azalea 964 • tessuto Tulipano 1013 • rivestimento schienale centrale Tulipano 1014 + rivestimento schienale basso e sedile Azalea 600, base alluminio
Presidential + executive + manager armchairs / Azalea leather 964 • Tulipano fabric 1013 • upholstery back-middle side Tulipano 1014 + upholstery back-lower side and seat Azalea 600, aluminium base



CHARME

VIGANÒ EDITOR

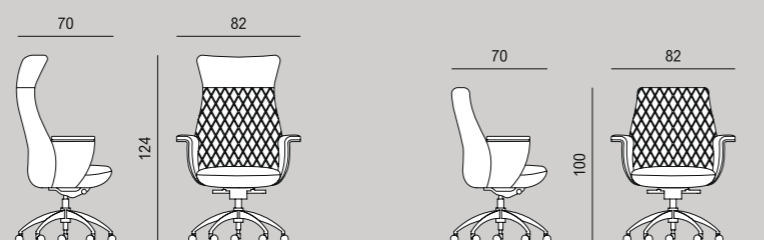

SEDUTA DIREZIONALE E SEMIDIREZIONALE | EXECUTIVE AND MANAGER ARMCHAIR







GRACE

VIGANÒ EDITOR

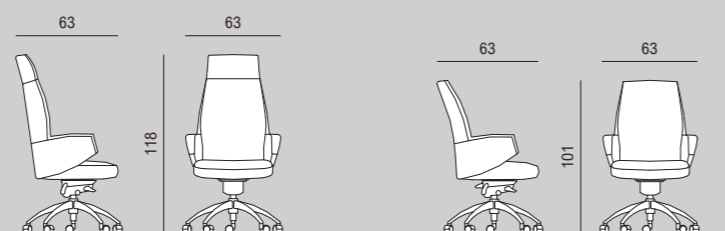

SEDUTA DIREZIONALE E SEMIDIREZIONALE | *EXECUTIVE AND MANAGER ARMCHAIR*

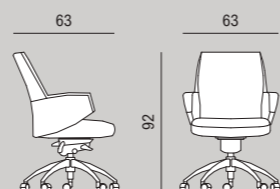

SEDUTA OPERATIVA, MEETING E VISITATORE | *TASK, MEETING AND VISITOR ARMCHAIR*

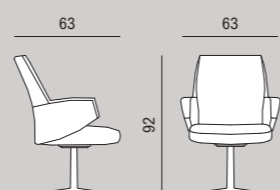

SEDUTA MEETING E VISITATORE | *MEETING AND VISITOR ARMCHAIR*









QUEEN 2022

REDESIGN **BASAGLIA + ROTA NODARI**

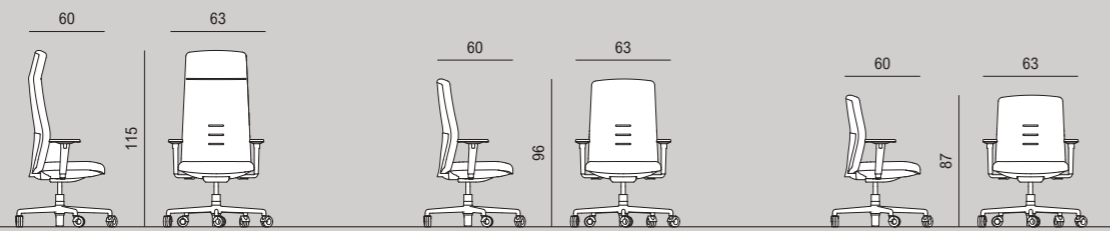

SEDUTA DIREZIONALE, SEMIDIREZIONALE E OPERATIVA IMBOTTITA | *PADDED EXECUTIVE, MANAGER AND TASK ARMCHAIR*

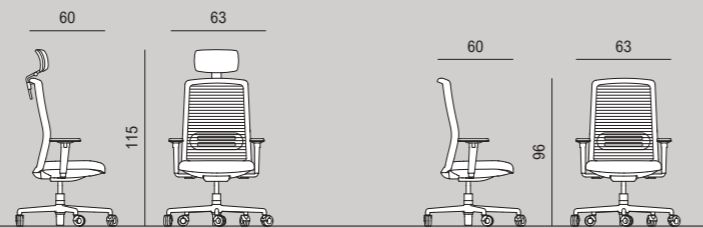

SEDUTA DIREZIONALE E OPERATIVA IN RETE | *EXECUTIVE AND TASK ARMCHAIR, MESH BACKREST*

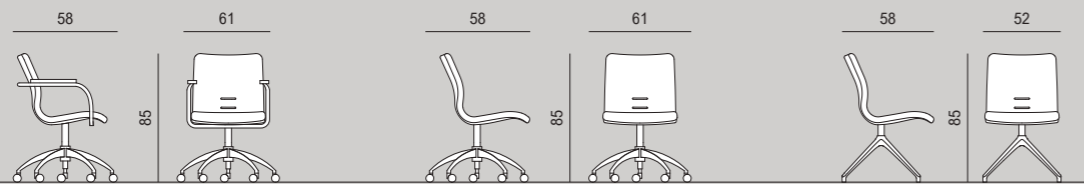

SEDUTA MEETING | *MEETING ARMCHAIR*

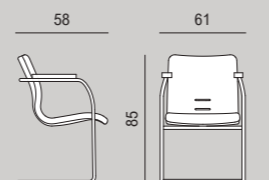

SEDUTA VISITATORE CANTILEVER | *VISITOR CHAIR, SKID FRAME*















QUEEN mesh

VIGANÒ EDITOR

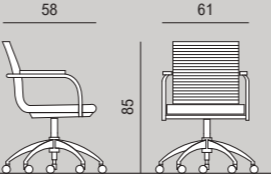

SEDUTA MEETING | MEETING ARMCHAIR

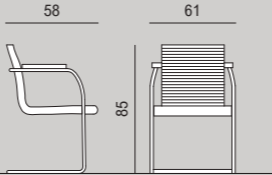

SEDUTA VISITATORE CANTILEVER | VISITOR CHAIR, SKID FRAME





STAR

VIGANÒ EDITOR

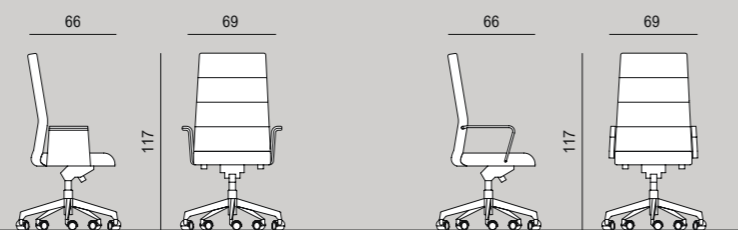

SEDUTA DIREZIONALE | EXECUTIVE ARMCHAIR

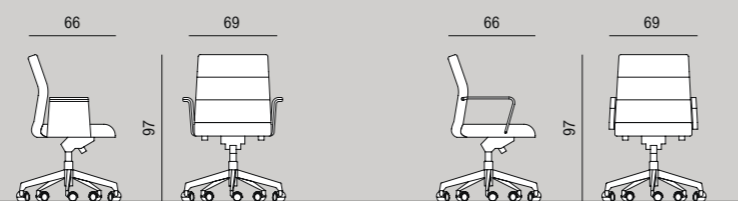

SEDUTA SEMIDIREZIONALE | MANAGER ARMCHAIR

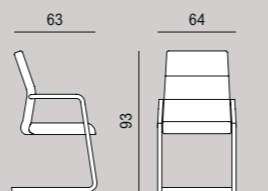

SEDUTA VISITATORE CANTILEVER | VISITOR CHAIR, SKID FRAME







LOGIKA

VIGANÒ EDITOR

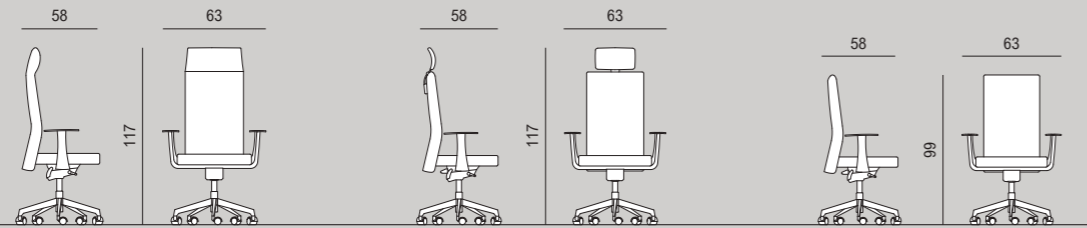

SEDUTA PRESIDENZIALE, DIREZIONALE E SEMIDIREZIONALE | *PRESIDENTIAL, EXECUTIVE AND MANAGER ARMCHAIR*



SEDUTA OPERATIVA IMBOTTITA E IN RETE | *PADDED AND MESH TASK ARMCHAIR*

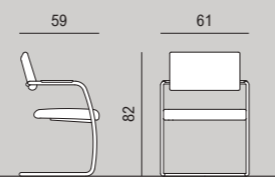

SEDUTA VISITATORE CANTILEVER | *VISITOR CHAIR, SKID FRAME*









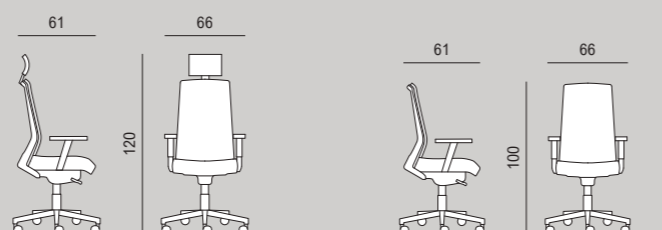

SEDUTA DIREZIONALE E OPERATIVA IMBOTTITA | *PADDED EXECUTIVE AND TASK ARMCHAIR*



SEDUTA ATTESA + SEDUTA VISITATORE CANTILEVER IMBOTTITA | *PADDED VISITOR CHAIR + PADDED VISITOR CHAIR, SKID FRAME*

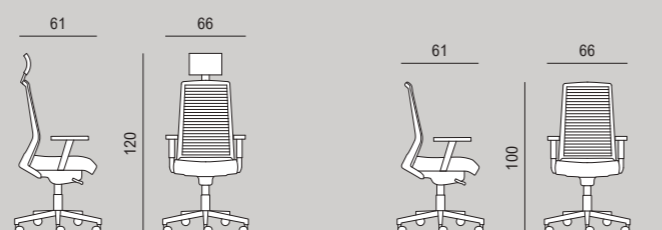

SEDUTA DIREZIONALE E OPERATIVA IN RETE | *EXECUTIVE AND TASK ARMCHAIR, MESH BACKREST*

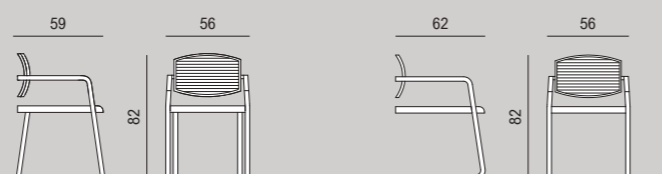

SEDUTA ATTESA + SEDUTA VISITATORE CANTILEVER IN RETE | *VISITOR CHAIR, MESH BACKREST 4 LEGS + SKID FRAME*









Seduta attesa e visitatore cantilever in rete + seduta direzionale e operativa in rete / tessuto Gelsomino 800 - 801, rete Mughetto 612, schienale bianco, struttura cromata, base bianca
Visitor chair, mesh backrest 4 legs and skid frame + executive and task armchair, mesh backrest / Gelsomino fabric 800 - 801, Mughetto mesh 612, white backrest, chromed frame, white base

CELO

R&D VIGANÒ

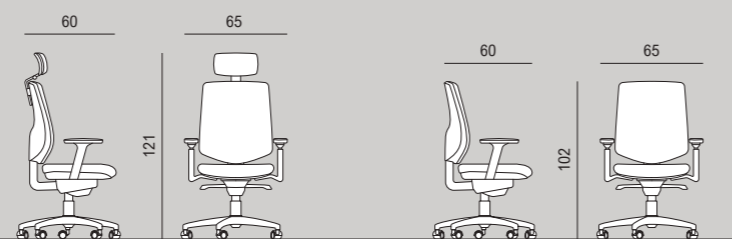

SEDUTA DIREZIONALE E OPERATIVA IMBOTTITA | *PADDED EXECUTIVE AND TASK ARMCHAIR*

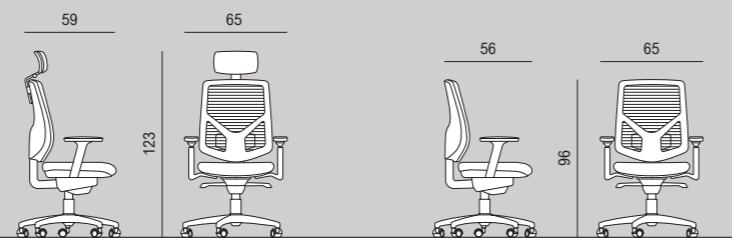

SEDUTA DIREZIONALE E OPERATIVA IN RETE | *EXECUTIVE AND TASK ARMCHAIR, MESH BACKREST*









OZIUM

R&D VIGANÒ

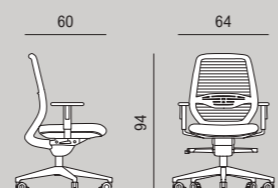

SEDUTA OPERATIVA | TASK ARMCHAIR





Famiglia / tessuto Gelsomino 873 + rete Mughetto 615 + basi nere + struttura nera • tessuto Gelsomino 800 - 801 + rete Mughetto 614 + basi bianche + struttura bianca
Family / Gelsomino fabric 873 + Mughetto mesh 615 + black bases + black frame • Gelsomino fabric 800 - 801 + Mughetto mesh 614 + white bases + white frame

BEO
R&D VIGANÒ

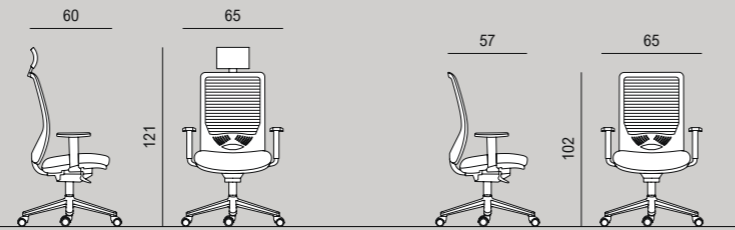

SEDUTA DIREZIONALE E OPERATIVA | EXECUTIVE AND TASK ARMCHAIR





MARY

R&D VIGANÒ

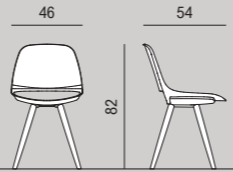

SEDUTA VISITATORE | VISITOR CHAIR

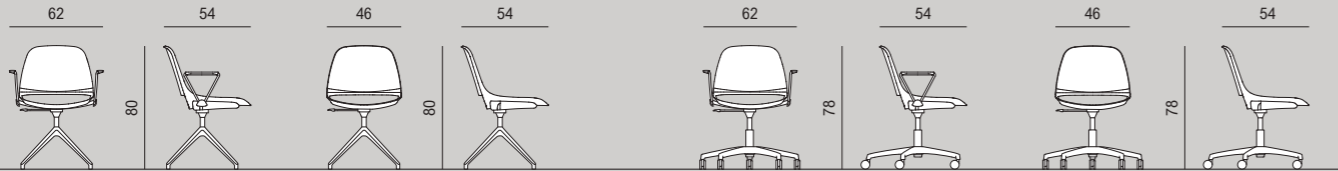

SEDUTA MEETING CON E SENZA BRACCIOLI | MEETING CHAIR WITH AND WITHOUT ARMRESTS







KATE

R&D VIGANÒ

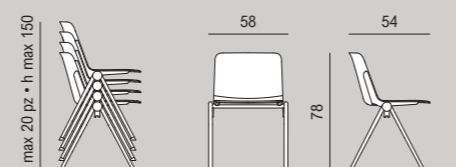

SEDUTA ATTESA | VISITOR CHAIR

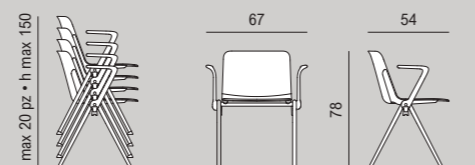

SEDUTA ATTESA CON BRACCIOLI | VISITOR CHAIR WITH ARMRESTS





MADAM collettività

DESIGN ROBERTO MOLteni + IVO PELLEGRi

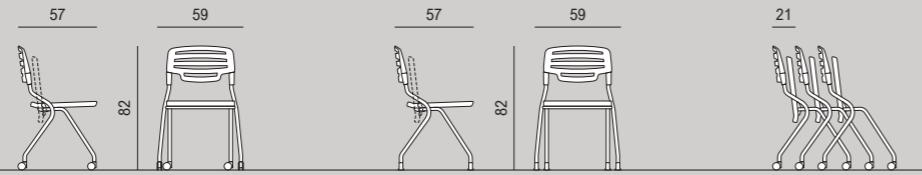

SEDUTA ATTESA RIBALTABILE | VISITOR CHAIR WITH FOLDING SEAT

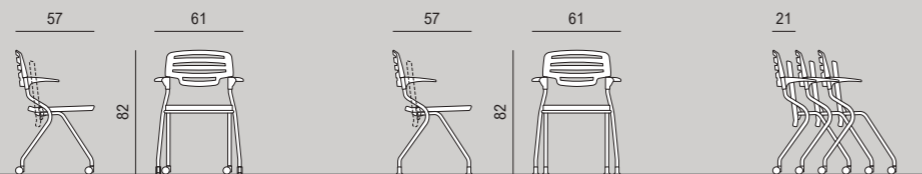

SEDUTA ATTESA RIBALTABILE CON BRACCIOLI | VISITOR CHAIR WITH FOLDING SEAT AND ARMRESTS

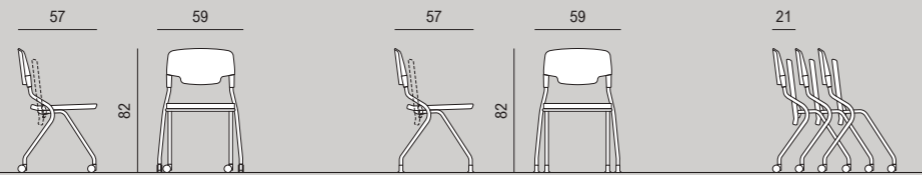

SEDUTA ATTESA RIBALTABILE IMBOTTITA | PADDED VISITOR CHAIR WITH FOLDING SEAT

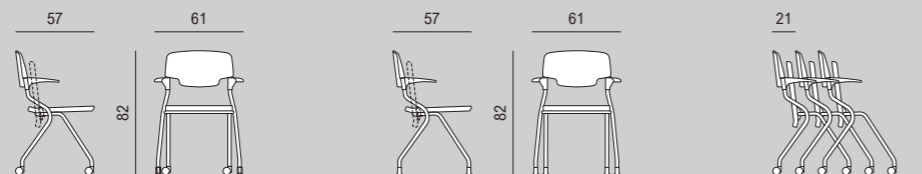

SEDUTA ATTESA RIBALTABILE IMBOTTITA CON BRACCIOLI | PADDED VISITOR CHAIR WITH FOLDING SEAT AND ARMRESTS





Famiglia / tessuto Tulipano 1005 - 1003 - 1004 - 1013 - 1012 - 1014 - 1015, plastica nera - RAL1013 - RAL7012, struttura verniciata RAL9005 - RAL7043 o cromata
Family / Tulipano fabric 1005 - 1003 - 1004 - 1013 - 1012 - 1014 - 1015, black - RAL1013 - RAL7012 plastic, epoxy powder coated RAL9005 - RAL7043 or chromed frame



Seduta attesa plastica con e senza braccioli / tessuto Tulipano 1012 - 1015 - 1014, plastica RAL1013 - nero - RAL7012, struttura cromata o verniciata RAL9005 - RAL7043
Plastic visitor chair with and without armrests / Tulipano fabric 1012 - 1015 - 1014, RAL1013 - black - RAL7012 plastic, chromed or epoxy powder coated frame RAL9005 - RAL7043

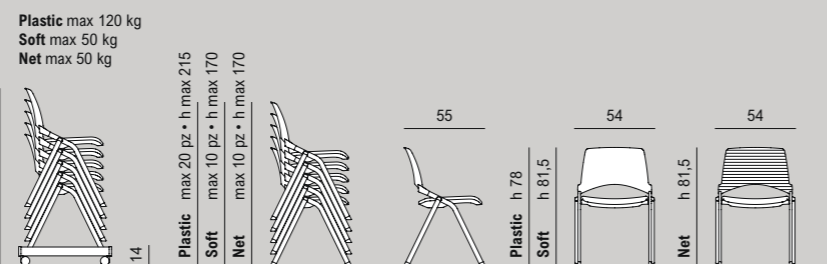

SEDUTA ATTESA | VISITOR CHAIR

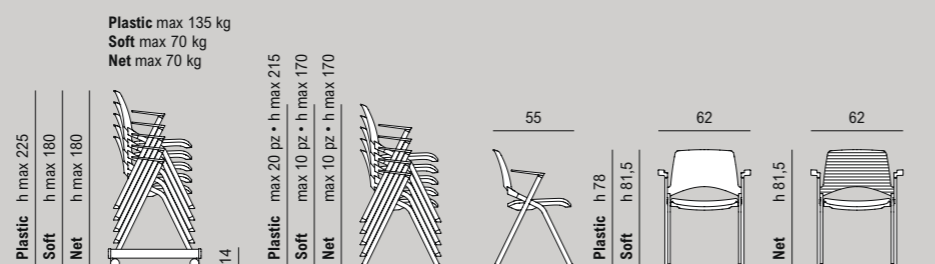

SEDUTA ATTESA CON BRACCIOLI | VISITOR CHAIR WITH ARMRESTS

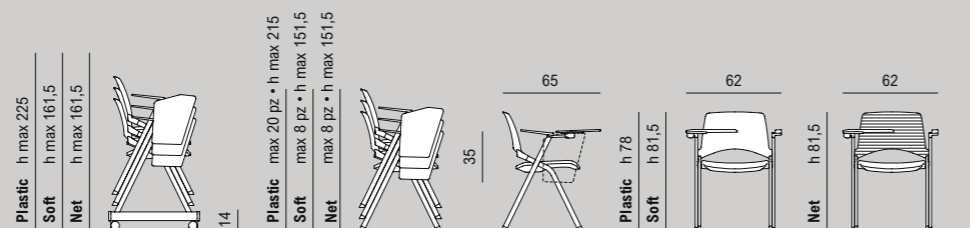

SEDUTA TRAINING | TRAINING CHAIR









Plastic max 40
Soft max 15
max 350 kg

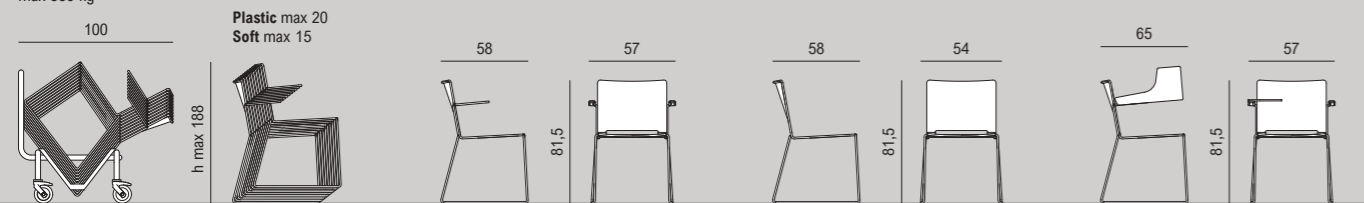

SEDUTA ATTESA CON E SENZA BRACCIOLI + TRAINING CHAIR | VISITOR CHAIR WITH AND WITHOUT ARMRESTS + TRAINING CHAIR

Plastic max 15
Soft max 10



SEDUTA ATTESA 4 GAMBE | VISITOR CHAIR, 4 LEGS FRAME



SEDUTA MEETING CON E SENZA BRACCIOLI | MEETING CHAIR WITH AND WITHOUT ARMRESTS

Plastic max 15
Soft max 10

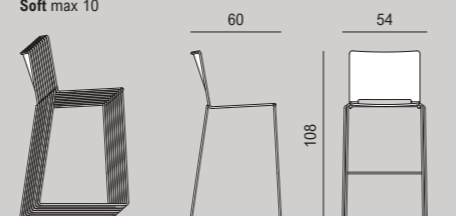

SGABELLO | STOOL

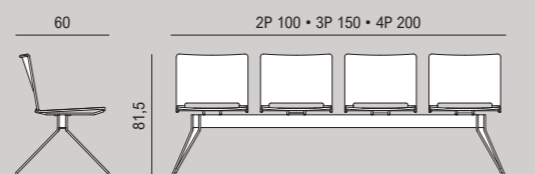

PANCA | BENCH

DAISY

DESIGN BASAGLIA + ROTA NODARI











DAISY metal

DESIGN BASAGLIA + ROTA NODARI

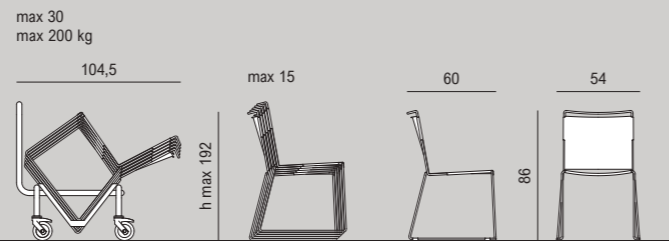

SEDUTA ATTESA | VISITOR CHAIR

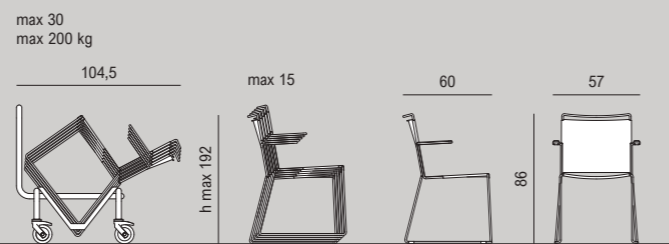

SEDUTA ATTESA CON BRACCIOLI | VISITOR CHAIR WITH ARMRESTS

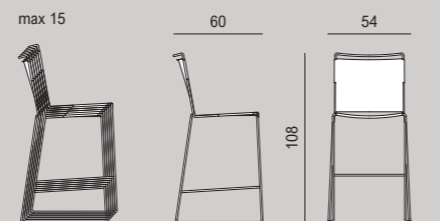

SGABELLO | STOOL





Seduta attesa in metallo con e senza braccioli / struttura verniciata + scocca in alluminio RAL9005 • RAL7004 • RAL7043 • RAL1019 • RAL6021 • RAL9003 • RAL2012 • RAL1004 • RAL3020
Metal visitor chair with and without armrests / epoxy powder coated frame + aluminium shell RAL9005 • RAL7004 • RAL7043 • RAL1019 • RAL6021 • RAL9003 • RAL2012 • RAL1004 • RAL3020



Seduta attesa in metallo con braccioli / struttura verniciata + scocca in alluminio RAL2012 • RAL6021 • RAL1019 • RAL7004 • RAL7043 • RAL9005
• RAL1004 • RAL9003 • RAL3020
Metal visitor chair with armrests / epoxy powder coated frame + aluminium shell RAL2012 • RAL6021 • RAL1019 • RAL7004 • RAL7043 • RAL9005
• RAL1004 • RAL9003 • RAL3020

TED + TED up

DESIGN BASAGLIA + ROTA NODARI

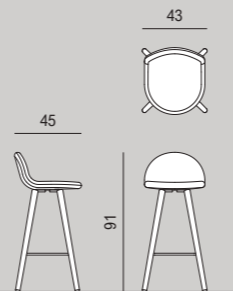

SGABELLO | *STOOL*

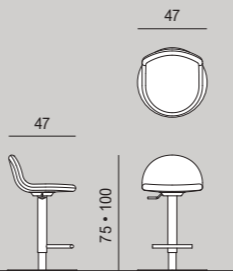

SGABELLO REGOLABILE | *UP-STOOL*







JOE

DESIGN **BASAGLIA + ROTA NODARI**

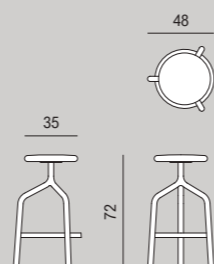

SGABELLO | *STOOL*

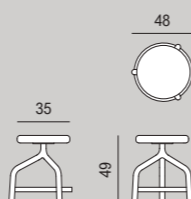

SGABELLO BASSO | *LOW-STOOL*

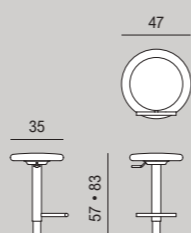

SGABELLO REGOLABILE | *UP-STOOL*





Sgabello / tessuto Tulipano 1016 + struttura verniciata RAL7004 • Tulipano 1017 + RAL7043 • Tulipano 1006 + RAL9003 • Tulipano 1002 + RAL2012
• Tulipano 1000 + RAL1004 • Tulipano 1003 + RAL3020 • Tulipano 1011 + RAL6021 • Tulipano 1015 + RAL9005 • Tulipano 1008 + RAL1019
Stool / Tulipano fabric 1016 + epoxy powder coated frame RAL7004 • Tulipano 1017 + RAL7043 • Tulipano 1006 + RAL9003 • Tulipano 1002 +
RAL2012 • Tulipano 1000 + RAL1004 • Tulipano 1003 + RAL3020 • Tulipano 1011 + RAL6021 • Tulipano 1015 + RAL9005 • Tulipano 1008 + RAL1019



Sgabello + sgabello basso / tessuto Tulipano 1002 + struttura verniciata RAL2012 • 1006 + RAL9003 • 1000 + RAL1004 • 1003 + RAL3020 • 1017 + RAL7043
Stool + Low-stool / Tulipano fabric 1002 + epoxy powder coated frame RAL2012 • 1006 + RAL9003 • 1000 + RAL1004 • 1003 + RAL3020 • 1017 + RAL7043



Sgabello regolabile / tessuto Tulipano 1015 + struttura verniciata RAL9005 • Tulipano 1008 + RAL1019 • Tulipano 1006 + RAL9003 • Tulipano 1002 + RAL2012 • Tulipano 1000 + RAL1004 • Tulipano 1003 + RAL3020 • Tulipano 1017 + RAL7043 • Tulipano 1016 + RAL7004 • Tulipano 1011 + RAL6021
Up-stool / Tulipano fabric 1015 + epoxy powder coated frame RAL9005 • Tulipano 1008 + RAL1019 • Tulipano 1006 + RAL9003 • Tulipano 1002 + RAL2012 • Tulipano 1000 + RAL1004 • Tulipano 1003 + RAL3020 • Tulipano 1017 + RAL7043 • Tulipano 1016 + RAL7004 • Tulipano 1011 + RAL6021

SHAKE

R&D VIGANÒ

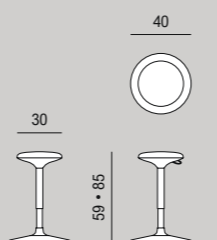

SGABELLO | STOOL



ERMES

DESIGN **BASAGLIA + ROTA NODARI**



TAVOLO | TABLE



CASSETTIERA | METAL DRAWERS





Famiglia / struttura in alluminio verniciata RAL9003 + piano in HPL bianco • struttura in alluminio verniciata RAL9005 + piano in cristallo laccato nero • cassetiera in metallo verniciata RAL9005
Family / epoxy powder coated aluminium frame RAL9003 + white HPL table top • epoxy powder coated aluminium frame RAL9005 + black lacquered glass table top • epoxy powder coated metal drawers RAL9005

FRED

DESIGN **BASAGLIA + ROTA NODARI**

TAVOLO TONDO | *ROUND TABLE*

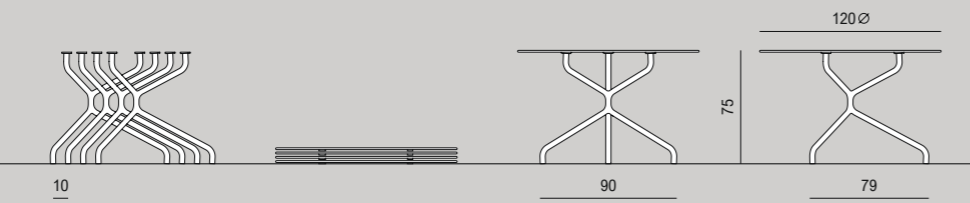

TAVOLO OVALE | *OVAL TABLE*

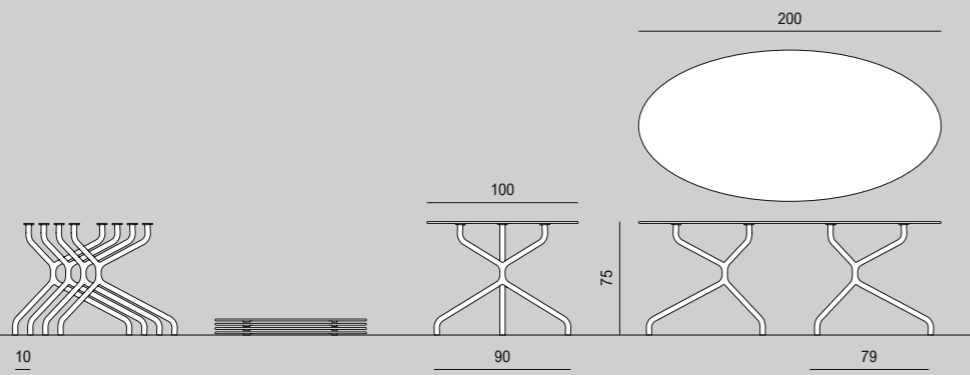





ARTURO

VIGANÒ EDITOR

TAVOLO RIBALTABILE | *FOLDING TABLE*

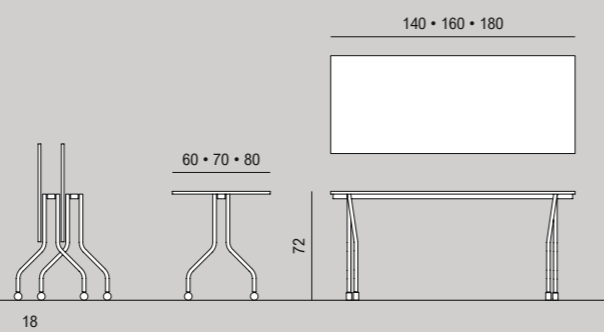





JACK

DESIGN **BASAGLIA + ROTA NODARI**

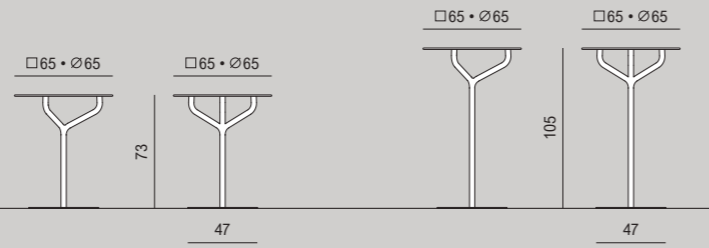

TAVOLO BAR (65x65 / ø65) | BAR TABLE (65x65 / ø65)

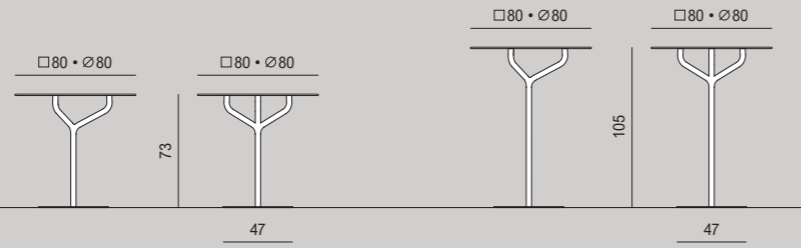

TAVOLO BAR (80x80 / ø80) | BAR TABLE (80x80 / ø80)





GINGER

DESIGN **BASAGLIA + ROTA NODARI**

TAVOLO BAR BASSO RIBALTABILE (65x65 / ø65)
LOW FOLDING BAR TABLE (65x65 / ø65)

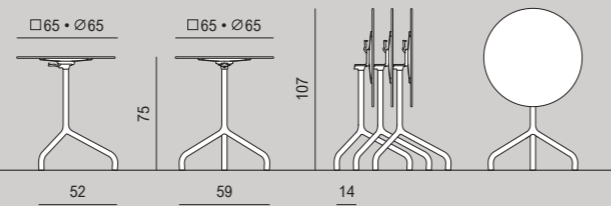

TAVOLO BAR ALTO RIBALTABILE (65x65 / ø65)
HIGH FOLDING BAR TABLE (65x65 / ø65)

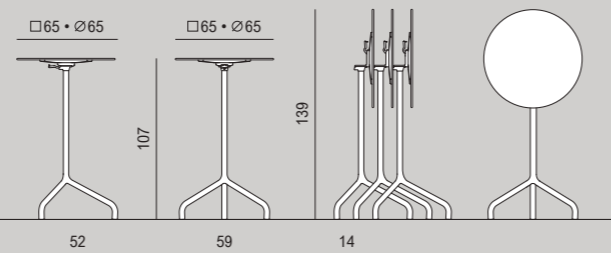

TAVOLO BAR BASSO RIBALTABILE (ø80)
LOW FOLDING BAR TABLE (ø80)

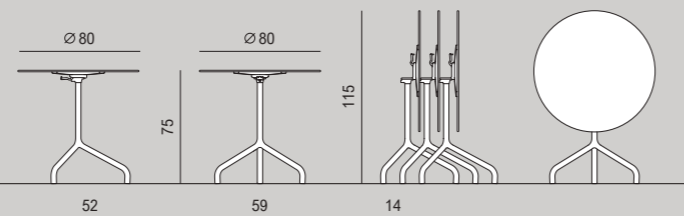

TAVOLO BAR ALTO RIBALTABILE (ø80)
HIGH FOLDING BAR TABLE (ø80)

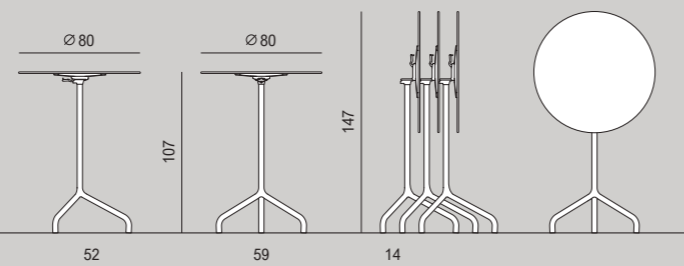



Famiglia / struttura verniciata RAL9005 + piano tavolino Vitter nero • RAL7043 + Vitter grigio antracite • RAL1019 + Vitter sabbia • RAL3020 + Vitter rosso • RAL1004 + Vitter giallo • RAL9003 + Vitter bianco
Family / epoxy powder coated frame RAL9005 + black Vitter service table top • RAL7043 + anthracite grey Vitter • RAL1019 + sand Vitter • RAL3020 + red Vitter • RAL1004 + yellow Vitter • RAL9003 + white Vitter



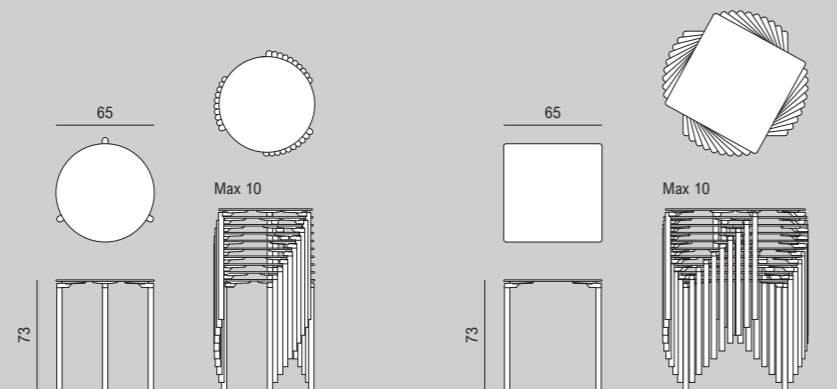

TAVOLO BAR (65x65 / ø65) | BAR TABLE (65x65 / ø65)

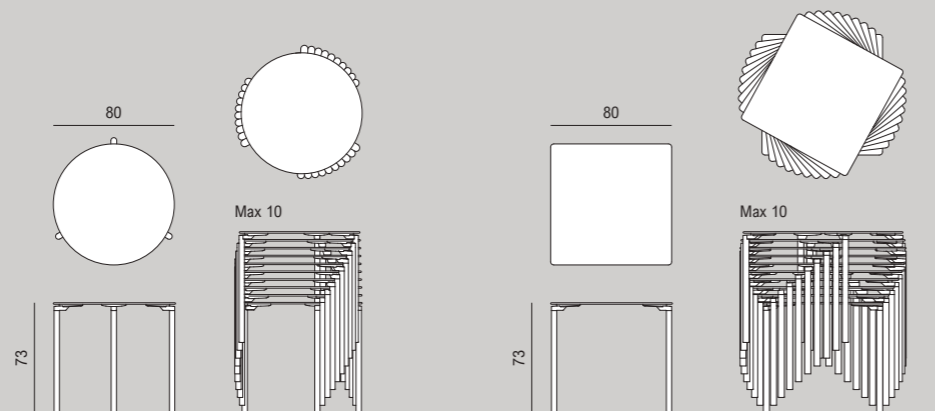

TAVOLO BAR (80x80 / ø80) | BAR TABLE (80x80 / ø80)





Famiglia / struttura verniciata RAL3020 + piano tavolino Vitter rosso • RAL2012 + Vitter arancione • RAL1004 + Vitter giallo • RAL6021 + Vitter verde salvia • RAL9003 + Vitter bianco • RAL1019 + Vitter sabbia • RAL9005 + Vitter nero • RAL7043 + Vitter grigio antracite • RAL7004 + Vitter grigio perla
Family / epoxy powder coated frame RAL3020 + red Vitter service table top • RAL2012 + orange Vitter • RAL1004 + yellow Vitter • RAL6021 + sage green Vitter • RAL9003 + white Vitter • RAL1019 + sand Vitter • RAL9005 + black Vitter • RAL7043 + anthracite grey Vitter • RAL7004 + pearl grey Vitter

APOLLO

VIGANÒ EDITOR

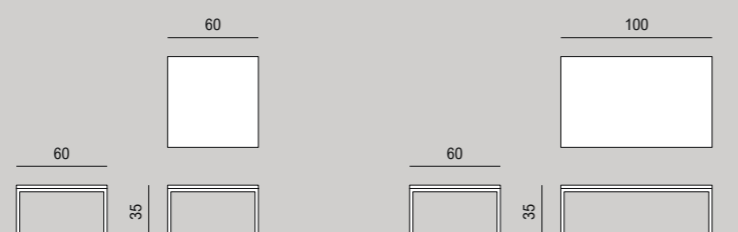

TAVOLINO BASSO | *LOW SERVICE TABLE*

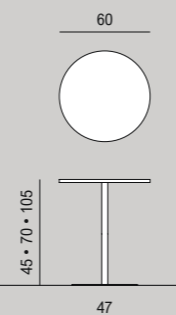

TAVOLINO ALTO BASE TONDA | *HIGH SERVICE TABLE WITH ROUND BASE*





STILO

DESIGN **BASAGLIA + ROTA NODARI**

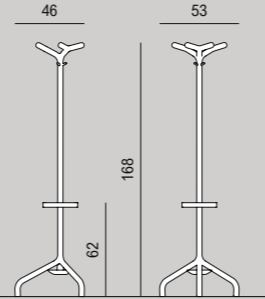

APPENDIABITI A TERRA | COAT HANGER ON FLOOR



APPENDIABITI A PARETE | WALL COAT HANGER







Campionario tessuti/ *Fabric samples*

LEGENDA *Legend*

-  Outdoor
Outdoor
-  Riciclabile
Recyclable
-  Tessuto ignifugo
Fire retardant fabric
-  Vera pelle
Real leather

Manutenzione e lavaggio / *Cleaning and washing*



Lavare a mano
Hand wash



Non lavare in acqua
Do not wash



Lavare max 30°C
Wash max 30°C



Lavare max 40°C
Wash max 40°C



Lavare max 60°C
Wash max 60°C



No asciugatrice
Do not tumble dry



Asciugare senza strizzare
Drip dry



Non stirare
Do not iron



Stirare max 110°C
Iron max 110°C



Non candeggiare
Do not bleach



Non lavare a secco
Do not dry clean



Lavaggio a secco solo con PCE
Dry cleaning only with PCE



Lavaggio delicato a secco solo con PCE
Delicate dry cleaning only with PCE

GELSOMINO / Cat. A

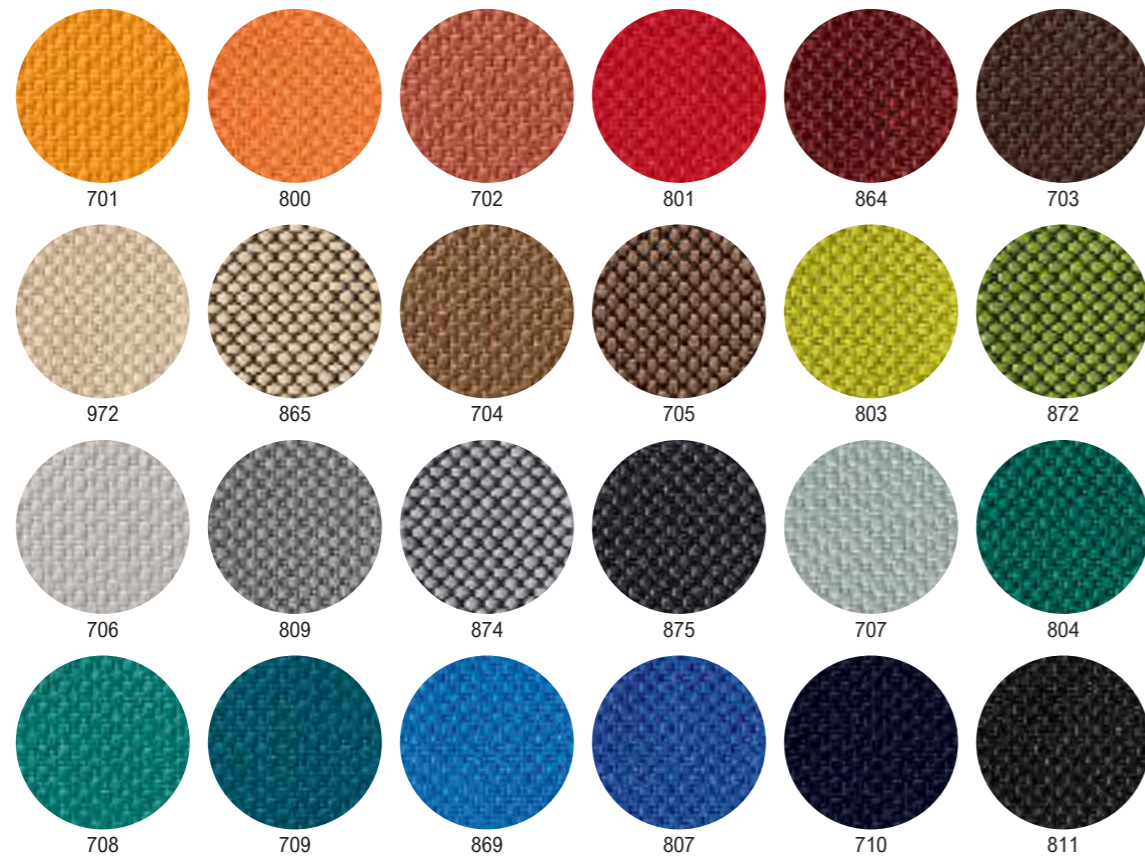

Composizione

100% Poliestere FR

Peso

560 ± 5% g/ml
400 ± 5% g/m2

Resistenza all'abrasione

(Martindale)
EN ISO 12947-2
80.000 ± 10% cicli

Pilling

EN ISO 12945-2
5 (foto standard)
Tolleranza: da 4 a 5

Solidità alla luce

EN ISO 105-B02
6 (scala blu)
Tolleranza: da 5 a 8

Solidità allo sfregamento

EN ISO 105-X12
4/5 (scala dei grigi)
Tolleranza: da 4 a 5

Reazione al fuoco

EN 1021/1-2
BS 5852 CRIB 5
BS 7176 Medium Hazard
NF P 92 501-7 M1
NF D 60013 AM 18
DIN 4102 Class B1
UNI 9174 Classe 1
UNI 9175 Classe 1IM
CAL TB 117:2013

Composition

100% Polyester FR

Weight

560 ± 5% g/ml
400 ± 5% g/m2

Abrasion resistance

(Martindale)
EN ISO 12947-2
80.000 ± 10% rubs

Pilling

EN ISO 12945-2
5 (standard pictures)
Tolerance: from 4 to 5

Light fastness

EN ISO 105-B02
6 (blue scale)
Tolerance: from 5 to 8

Fastness to rubbing

EN ISO 105-X12
4/5 (grey scale)
Tolerance: da 4 a 5

Flammability

EN 1021/1-2
BS 5852 CRIB 5
BS 7176 Medium Hazard
NF P 92 501-7 M1
NF D 60013 AM 18
DIN 4102 Class B1
UNI 9174 Classe 1
UNI 9175 Classe 1IM
CAL TB 117:2013

Manutenzione e lavaggio

Cleaning and washing



FIORDALISO / Cat. B



Composizione

90% P.V.C. - 10% Poliammide

Peso

700 g/mq

Resistenza all'abrasione

(Martindale)
UNI EN ISO 5470-2
Metodo 1 > 60.000
Metodo 2 > 200.000

Solidità alla luce

UNI EN ISO 105 B02
> 6

Solidità allo sfregamento

UNI EN ISO 105X12
4 - 5 (scala dei grigi)

Reazione al fuoco

BS 5852-1
IMO Resolution MSC.307 (88)
Ftp Code 2010 - Part 8
UNI 9175 Classe 1IM
NFP 92 507: M2
DIN 4102-1: B2
FAR 25.853

Composition

90% P.V.C. - 10% Polyamide

Weight

700 g/mq

Abrasion resistance

(Martindale)
UNI EN ISO 5470-2
Metodo 1 > 60.000
Metodo 2 > 200.000

Light fastness

UNI EN ISO 105 B02
> 6

Fastness to rubbing

UNI EN ISO 105X12
4 - 5 (grey scale)

Flammability

BS 5852-1
IMO Resolution MSC.307 (88)
Ftp Code 2010 - Part 8
UNI 9175 Classe 1IM
NFP 92 507: M2
DIN 4102-1: B2
FAR 25.853 i

Manutenzione e lavaggio

Cleaning and washing



TULIPANO / Cat. B

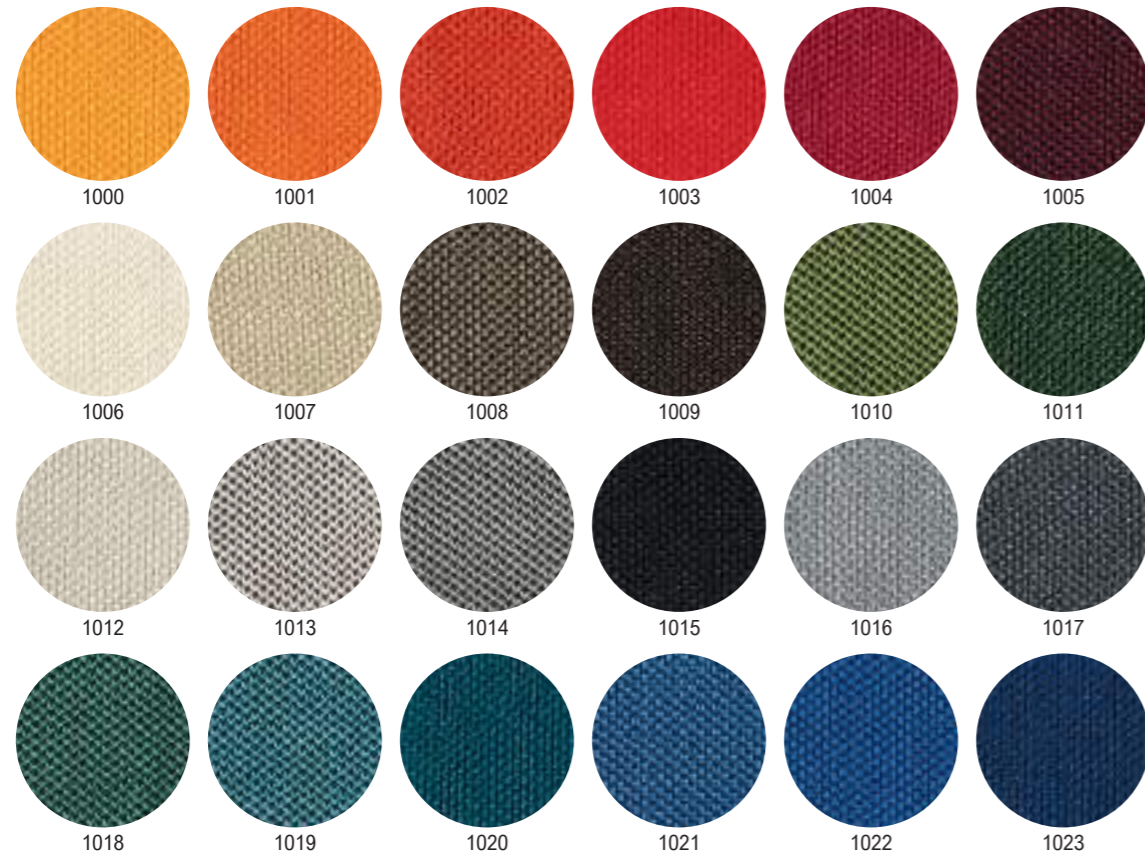

Composizione
100% Poliestere Riciclato

Peso
525 ± 5% g/ml
350 ± 5% g/m²

Resistenza all'abrasione
(Martindale)
UNI EN ISO 12947/2
100.000 ± 10% cicli

Pilling
UNI EN ISO 12945/2
5 (foto standard)
Tolleranza: da 4 a 5

Solidità alla luce
UNI EN ISO 105-B02
6 (scala blu)
Tolleranza: da 5 a 8

Solidità allo sfregamento
UNI EN ISO 105-X12
4/5 (scala dei grigi)
Tolleranza: da 4 a 5

Reazione al fuoco
EN 1021/1-2
CRIB 5
BS 7176 Medium Hazard
California TB117
UNI 9175 Classe 1IM

Composition
100% Recycled Polyester

Weight
525 ± 5% g/ml
350 ± 5% g/m²

Abrasion resistance
(Martindale)
UNI EN ISO 12947/2
100.000 ± 10% rubs

Pilling
UNI EN ISO 12945/2
5 (standard pictures)
Tolerance: from 4 to 5

Light fastness
UNI EN ISO 105-B02
6 (blue scale)
Tolerance: from 5 to 8

Fastness to rubbing
UNI EN ISO 105-X12
4/5 (grey scale)
Tolerance: from 4 to 5

Flammability
EN 1021/1-2
CRIB 5
BS 7176 Medium Hazard
California TB117
UNI 9175 Classe 1IM

Manutenzione e lavaggio
Cleaning and washing

TULIPANO Plus / Cat. B

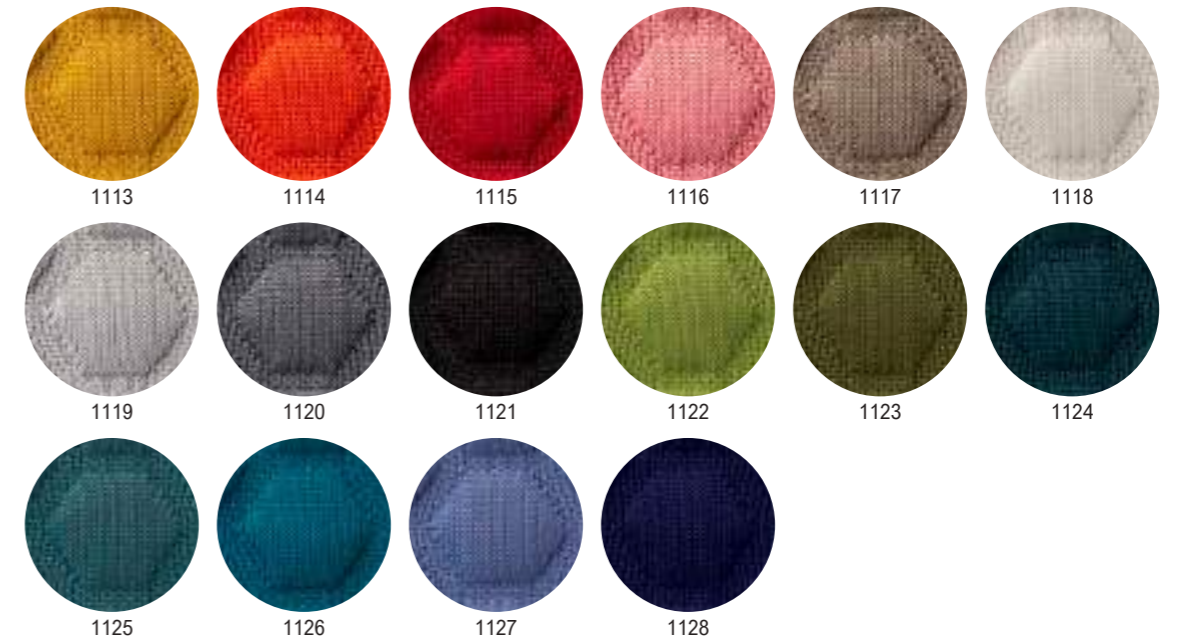

Composizione
100% Poliestere Riciclato

Peso
890 ± 5% g/ml
635 ± 5% g/m²

Resistenza all'abrasione
(Martindale)
EN ISO 12947-2
50.000 ± 10% cicli

Pilling
EN ISO 12945-2
5 (foto standard)
Tolleranza: da 4 a 5

Solidità alla luce
EN ISO 105-B02
6 (scala blu)
Tolleranza: da 5 a 8

Solidità allo sfregamento
EN ISO 105-X12
4/5 (scala dei grigi)
Tolleranza: da 4 a 5

Camera riverberante
EN ISO 354
0,75 (α_w)

Reazione al fuoco
EN 1021/1-2
BS 7176 Low Hazard
UNI 9175 Classe 1IM
CAL TB 117:2013

Composition
100% Recycled Polyester

Weight
890 ± 5% g/ml
635 ± 5% g/m²

Abrasion resistance
(Martindale)
EN ISO 12947-2
50.000 ± 10% rubs

Pilling
EN ISO 12945-2
5 (standard pictures)
Tolerance: from 4 to 5

Light fastness
EN ISO 105-B02
6 (blue scale)
Tolerance: from 5 to 8

Fastness to rubbing
EN ISO 105-X12
4/5 (grey scale)
Tolerance: from 4 to 5

Reverberation room
EN ISO 354
0,75 (α_w)

Flammability
EN 1021/1-2
BS 7176 Low Hazard
UNI 9175 Classe 1IM
CAL TB 117:2013

Manutenzione e lavaggio
Cleaning and washing

AZALEA / Cat. C

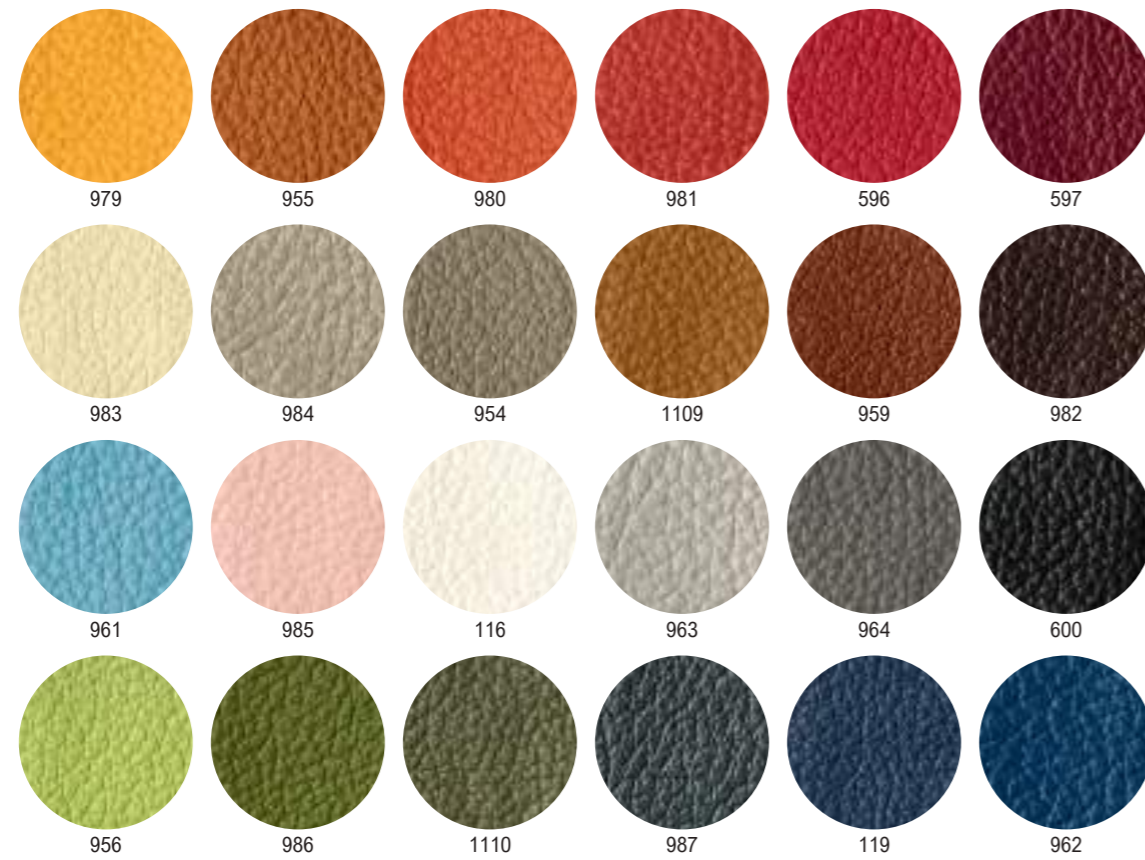

Composizione

100% Pelle bovina

Spessore

0,9 mm - 1,1 mm

Solidità alla luce

IUF 402 / UNI EN ISO 105-B02
5 (scala dei blu)

Solidità allo sfregamento

IUF UNI EN ISO 11640
> 4 (scala dei grigi)

Reazione al fuoco

UNI EN ISO 1021-1/2
BS 5852 1991 SEC.4 NI/0-1
California TB117

Manutenzione e lavaggio

Lavare con soluzione composta da
50% acqua e 50% latte detergente

Composition

100% Bovien leather

Thickness

0,9 mm - 1,1 mm

Light fastness

IUF 402 / UNI EN ISO 105-B02
5 (blue scale)

Fastness to rubbing

IUF UNI EN ISO 11640
> 4 (grey scale)

Flammability

UNI EN ISO 1021-1/2
BS 5852 1991 SEC.4 NI/0-1
California TB117

Cleaning and washing

Wash with a solution consisting of 50%
water and 50% cleansing milk

ORCHIDEA / Cat. E

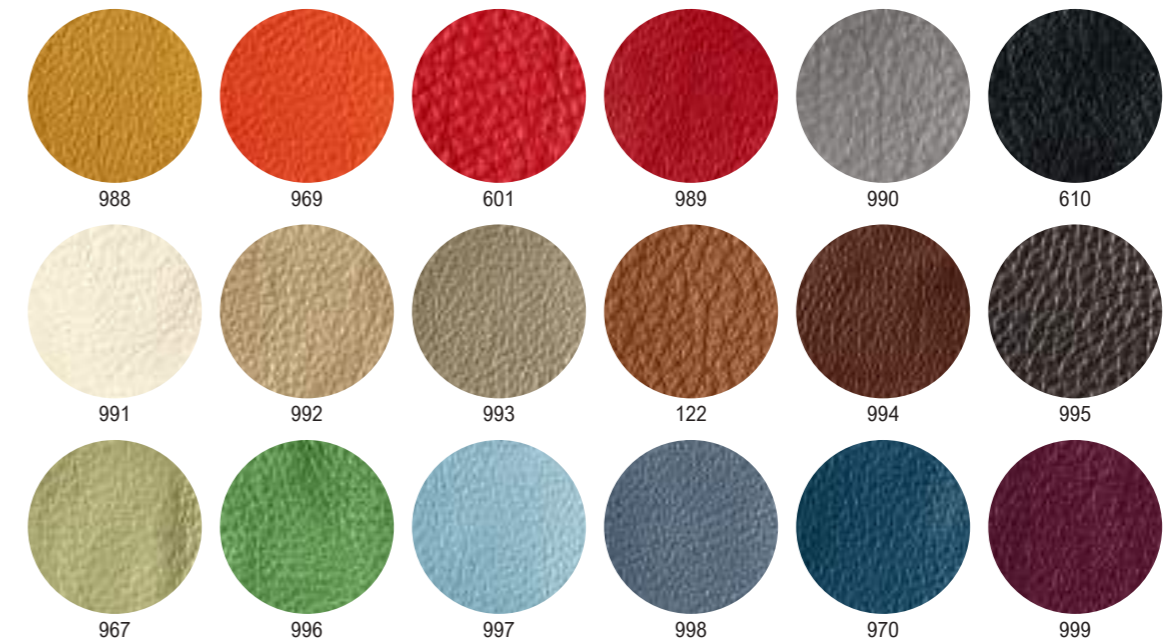

Composizione

100% Pelle bovina

Spessore

0,9 mm - 1,1 mm

Solidità alla luce

IUF 402 / UNI EN ISO 105-B02
5 (scala dei blu)

Solidità allo sfregamento

IUF UNI EN ISO 11640
> 4 (scala dei grigi)

Reazione al fuoco

UNI EN ISO 1021-1/2
BS 5852 1991 SEC.4 NI/0-1
California TB117

Manutenzione e lavaggio

Lavare con soluzione composta da
50% acqua e 50% latte detergente

Composition

100% Bovien leather

Thickness

0,9 mm - 1,1 mm

Light fastness

IUF 402 / UNI EN ISO 105-B02
5 (blue scale)

Fastness to rubbing

IUF UNI EN ISO 11640
> 4 (grey scale)

Flammability

UNI EN ISO 1021-1/2
BS 5852 1991 SEC.4 NI/0-1
California TB117

Cleaning and washing

Wash with a solution consisting of 50%
water and 50% cleansing milk

ORTENSIA / Cat. D

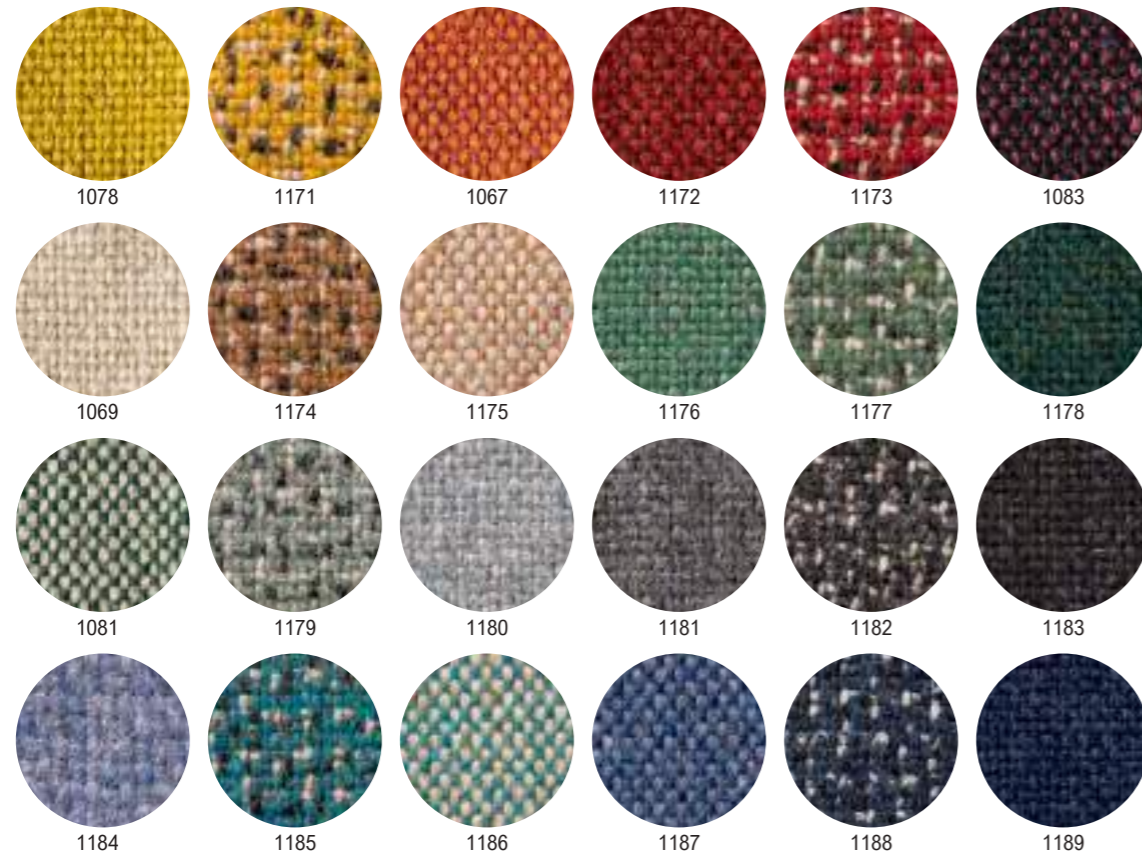

Composizione

75% Lana vergine - 25% Lino

Peso

440 g/mq

Resistenza all'abrasione

(Martindale)

UNI EN ISO 5470-2
50.000 cicli

Solidità alla luce

UNI EN ISO 105-B02
4 - 5

Solidità allo sfregamento

UNI EN ISO 105-X12
Umido: 3 - Secco: 4

Reazione al fuoco

EN 1021-1
EN 1021-2
BS 7176 Low Hazard
BS 5852 Ignition Source 5
BS 7176 Medium Hazard
NF D 60-013
ONORM B 3825 & A 3800-1
UNI 9175 Classe 1 IM
BS 476 PART 7 Class
EN 13501-1 Adhered Class B
BS 5867-2 Type B
IMO FTP Code

Composition

75% Virgin wool - 25% Flax

Weight

440 g/mq

Abrasion resistance

(Martindale)

UNI EN ISO 5470-2
50.000 cycles

Light fastness

UNI EN ISO 105-B02
4 - 5

Fastness to rubbing

UNI EN ISO 105-X12
Wet: 3 - Dry: 4

Flammability

EN 1021-1
EN 1021-2
BS 7176 Low Hazard
BS 5852 Ignition Source 5
BS 7176 Medium Hazard
NF D 60-013
ONORM B 3825 & A 3800-1
UNI 9175 Classe 1 IM
BS 476 PART 7 Class
EN 13501-1 Adhered Class B
BS 5867-2 Type B
IMO FTP Code

Manutenzione e lavaggio
Cleaning and washing



NARCISO / Cat. D



Composizione

100% Lana

Peso

825 ± 5% g/ml
550 ± 5% g/m²

Resistenza all'abrasione

(Martindale)

UNI EN ISO 12947/2
60.000 ± 10% cicli

Pilling

UNI EN ISO 12945/2
4 (foto standard)
Tolleranza: da 4 a 5

Solidità alla luce

UNI EN ISO 105-B02
6 (scala blu)
Tolleranza: da 5 a 8

Solidità allo sfregamento

UNI EN ISO 105-X12
4/5 (scala dei grigi)
Tolleranza: da 4 a 5

Reazione al fuoco

UNI 9175 Class 1 IM
NF D 60013 Class AM 18
CRIB 5
BS EN 1021/1-2
Cal. Tec. Bull. 117

Composition

100% Wool

Weight

825 ± 5% g/ml
550 ± 5% g/m²

Abrasion resistance

(Martindale)

UNI EN ISO 12947/2
60.000 ± 10% rubs

Pilling

UNI EN ISO 12945/2
4 (standard pictures)
Tolerance: from 4 to 5

Light fastness

UNI EN ISO 105-B02
6 (blue scale)
Tolerance: from 5 to 8

Fastness to rubbing

UNI EN ISO 105-X12
4/5 (grey scale)
Tolerance: from 4 to 5

Flammability

UNI 9175 Class 1 IM
NF D 60013 Class AM 18
CRIB 5
BS EN 1021/1-2
Cal. Tec. Bull. 117

Manutenzione e lavaggio
Cleaning and washing



DALIA / Cat. D



Composizione
100% Poliestere Trevira CS®

Peso
1290 ± 5% g/ml
920 ± 5% g/m²

Resistenza all'abrasione
(Martindale)
EN ISO 12947-2
120.000 ± 10% cicli

Pilling
EN ISO 12945-2
5 (foto standard)
Tolleranza: da 4 a 5

Solidità alla luce
EN ISO 105-B02
6 (scala blu)
Tolleranza: da 5 a 8

Solidità allo sfregamento
EN ISO 105-X12
4/5 (scala dei grigi)
Tolleranza: da 4 a 5

Reazione al fuoco
EN 1021/1-2
BS 7176 Low Hazard
NF P 92 501-7 M1
NF D 60013 AM 18
DIN 4102 Class B1
UNI 9174 Classe 1
UNI 9175 Classe 1IM
CAL TB 117:2013
IMO Part 8 Upholstery

Composition
100% Polyester Trevira CS®

Weight
1290 ± 5% g/ml
920 ± 5% g/m²

Abrasion resistance
(Martindale)
EN ISO 12947-2
120.000 ± 10% rubs

Pilling
EN ISO 12945-2
5 (standard pictures)
Tolerance: from 4 to 5

Light fastness
EN ISO 105-B02
6 (blue scale)
Tolerance: from 5 to 8

Fastness to rubbing
EN ISO 105-X12
4/5 (grey scale)
Tolerance: from 4 to 5

Flammability
EN 1021/1-2
BS 7176 Low Hazard
NF P 92 501-7 M1
NF D 60013 AM 18
DIN 4102 Class B1
UNI 9174 Classe 1
UNI 9175 Classe 1IM
CAL TB 117:2013
IMO Part 8 Upholstery

Manutenzione e lavaggio
Cleaning and washing



IRIS / Cat. D



Composizione
100% Poliolefinica FR

Peso
515 g/mq

Resistenza all'abrasione
(Martindale)
UNI EN ISO 12947
> 40.000 cicli

Solidità alla luce
UNI EN ISO 105 B02
6 - 7

Solidità allo sfregamento
UNI EN ISO 105-X12
4

Reazione al fuoco
UNI 8456-9174 Class 1
BS EN 1021.1
BS EN 1021.2
T.B.117 (2013)
B1 ACCORDING TO DIN 4102
NEPA 260:2013
IMO 2010 FTP CODE PART 8
EN 13773 (2004) Classe 1

Composition
100% Polyolefinic FR

Weight
515 g/mq

Abrasion resistance
(Martindale)
UNI EN ISO 12947
> 40.000 cycles

Light fastness
UNI EN ISO 105 B02
6 - 7

Fastness to rubbing
UNI EN ISO 105-X12
4

Flammability
UNI 8456-9174 Class 1
BS EN 1021.1
BS EN 1021.2
T.B.117 (2013)
B1 ACCORDING TO DIN 4102
NEPA 260:2013
IMO 2010 FTP CODE PART 8
EN 13773 (2004) Classe 1

Manutenzione e lavaggio
Cleaning and washing



PETUNIA / Cat. D

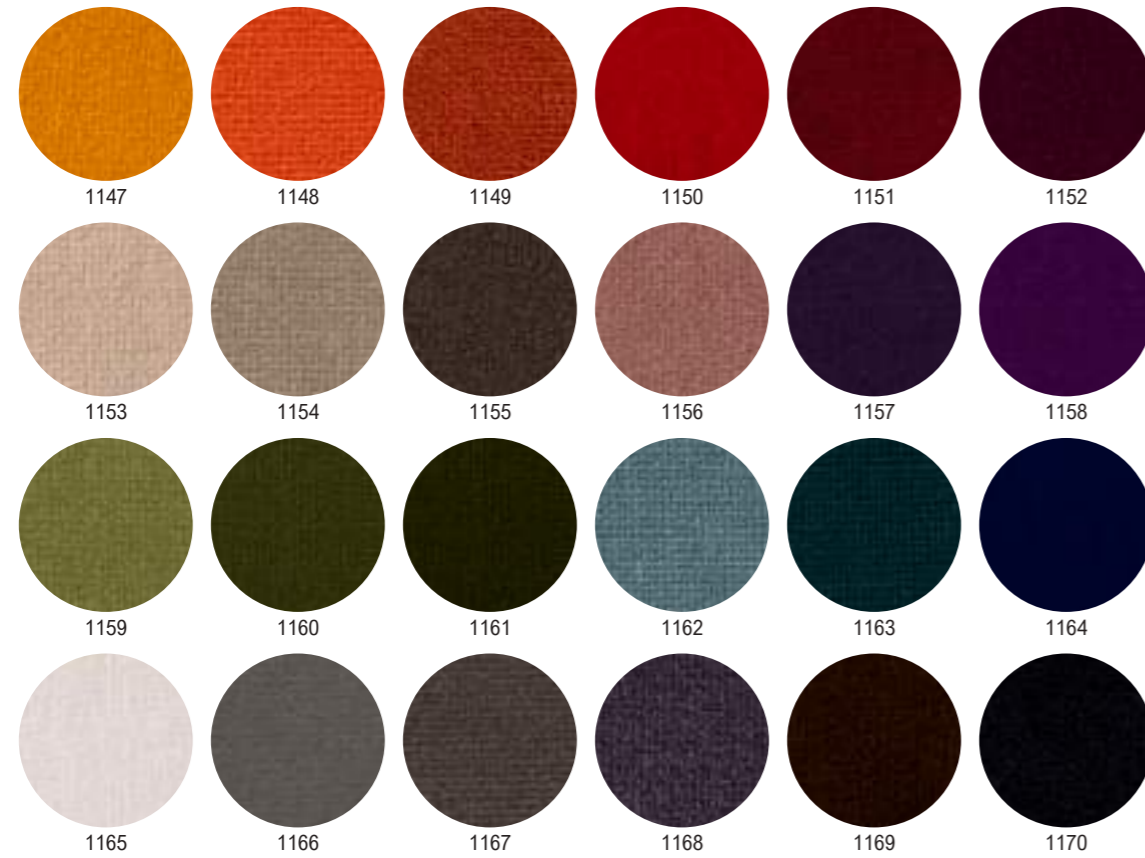

Composizione

100% Cotone

Peso

440 g/mq

Resistenza all'abrasione

(Martindale)

UNI EN ISO 5470-2

65.000 cicli

Solidità alla luce

UNI EN ISO 105 B02

5

Solidità allo sfregamento

UNI EN ISO 105-X12

Umido: 4 - Secco: 5

Reazione al fuoco

TB 117:2013

EN 1021-1

Ignifugo Classe 1IM (su richiesta)

Composition

100% Cotton

Weight

440 g/mq

Abrasion resistance

(Martindale)

UNI EN ISO 5470-2

65.000 cycles

Light fastness

UNI EN ISO 105 B02

5

Fastness to rubbing

UNI EN ISO 105-X12

Wet: 4 - Dry: 5

Flammability

TB 117:2013

EN 1021-1

Fireproof Class 1IM (upon request)

Manutenzione e lavaggio

Cleaning and washing





Campionario reti/ *Mesh samples*

LEGENDA *Legend*



Riciclabile
Recyclable



Tessuto ignifugo
Fire retardant fabric

Manutenzione e lavaggio / *Cleaning and washing*



Lavaggio delicato
Delicate washing



Lavare max 30°C
Wash max 30°C



Lavare max 40°C
Wash max 40°C



No asciugatrice
Do not tumble dry



Non stirare
Do not iron



Stirare max 110°C
Iron max 110°C



Non candeggiare
Do not bleach



Lavaggio a secco solo con PCE
Dry cleaning only with PCE



Lavaggio delicato a secco solo con PCE
Delicate dry cleaning only with PCE

GERANIO

Solo per collezione Omega / Only for collection Omega

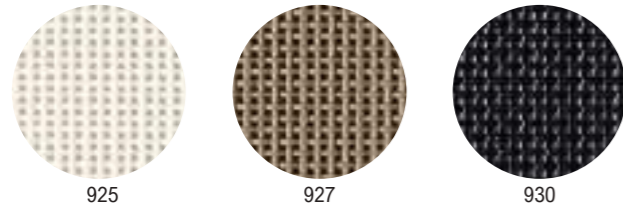

Composizione

Rete | 77% Polivinile - 23% Poliestere

Peso

560 g/mq

Resistenza all'abrasione

(Martindale)

UNI EN ISO 12947-2
100.000 cicli

Solidità allo sfregamento

UNI EN ISO 105X12
5

Reazione al fuoco

UNI 9175 Classe 1IM

Composition

Mesh | 77% Polyvinyl - 23% Polyester

Weight

560 g/mq

Abrasion resistance

(Martindale)

UNI EN ISO 12947-2
100.000 cycles

Fastness to rubbing

UNI EN ISO 105X12
5

Flammability

UNI 9175 Classe 1IM

Manutenzione e lavaggio
Cleaning and washing



GENZIANA

Solo per collezione Winner / Only for collection Winner

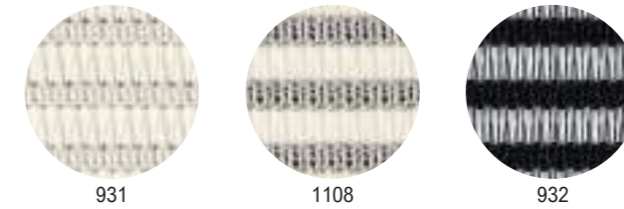

Composizione

Rete | 100% Poliestere

Peso

400 g/mq

Resistenza all'abrasione

(Martindale)

UNI EN ISO 12947-2
50.000 cicli

Solidità allo sfregamento

UNI EN ISO 105X12
Umido 4 - Secco 3

Reazione al fuoco

British standard cigarette test

Composition

Mesh | 100% Polyester

Weight

400 g/mq

Abrasion resistance

(Martindale)

UNI EN ISO 12947-2
50.000 cycles

Fastness to rubbing

UNI EN ISO 105X12
Wet 4 - Dry 3

Flammability

British standard cigarette test

Manutenzione e lavaggio
Cleaning and washing



MUGHETTO

Per le collezioni: Queen Mesh, Logika Rete, Time, Celo, Beo, Ken e Ozium
For collections: Queen Mesh, Logika Mesh, Time, Celo, Beo, Ken and Ozium

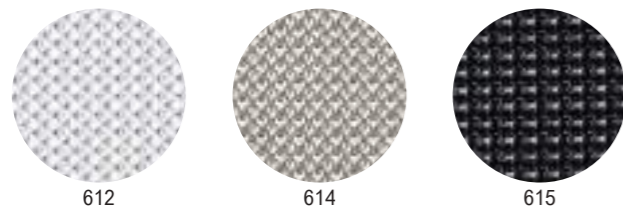

Composizione

Rete | 100% Poliestere

Peso

430 g/mq

Resistenza all'abrasione

(Martindale)

UNI EN ISO 12947-2
135.000 cicli

Solidità allo sfregamento

UNI EN ISO 105X12
Umido 4 - Secco 3

Reazione al fuoco

BS EN 1021-1
BS EN 1021-2
UNI 1975

Composition

Mesh | 100% Polyester

Weight

430 g/mq

Abrasion resistance

(Martindale)

UNI EN ISO 12947-2
135.000 cycles

Fastness to rubbing

UNI EN ISO 105X12
Wet 4 - Dry 3

Flammability

BS EN 1021-1
BS EN 1021-2
UNI 1975

Manutenzione e lavaggio
Cleaning and washing



OEKO-TEX®
CONFIDENCE IN TEXTILES
STANDARD 100
073313.0 CENTROCOT
Tested for harmful substances
www.oeko-tex.com/standard100

LILIU

Per le collezioni: Adele e Queen 2022
For collections: Adele and Queen 2022

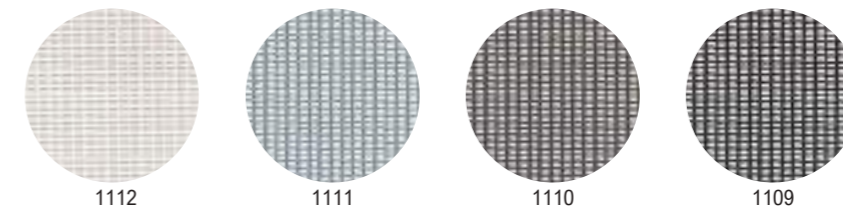

Composizione

Rete | 100% Poliestere

Peso

330 g/mq

Resistenza all'abrasione

(Martindale)

UNI EN ISO 12947-2
70.000 cicli

Solidità allo sfregamento

UNI EN ISO 105X12
Umido 4/5 - Secco 4/5

Reazione al fuoco

BS EN 1021-1
BS EN 1021-2

Composition

Mesh | 100% Polyester

Weight

330 g/mq

Abrasion resistance

(Martindale)

UNI EN ISO 12947-2
70.000 cycles

Fastness to rubbing

UNI EN ISO 105X12
Wet 4/5 - Dry 4/5

Flammability

BS EN 1021-1
BS EN 1021-2

Manutenzione e lavaggio
Cleaning and washing





Campionario finiture/ *Finishes samples*

METAL

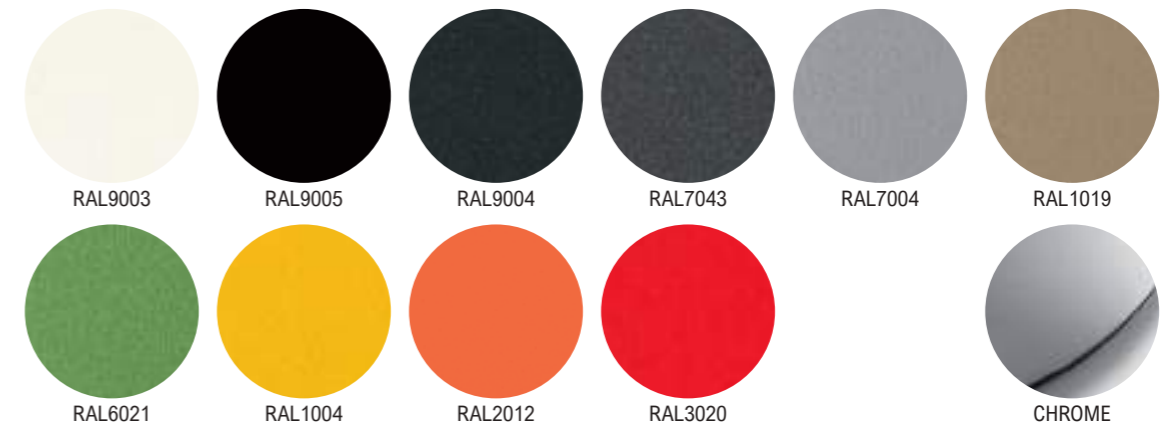

Vitter TABLE TOP



Hpl TABLE TOP

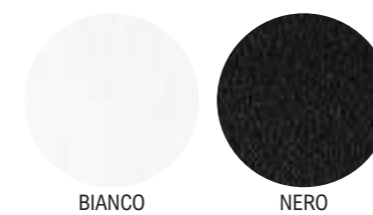

WOOD

Per le collezioni: Milly, Maggy e Ted
For collections: Milly, Maggy and Ted



Solo per collezione Grace
Only for collection Grace

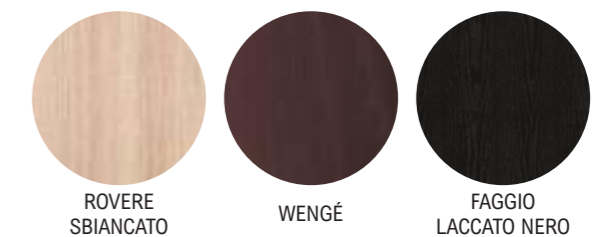



Art Direction

Alberto Basaglia

Concept and graphic design

Alberto Basaglia Natalia Rota Nodari
Architetti Associati

Photo

Carlos&Dario Tettamanzi

Print

Grafiche Gemma

Viganò si riserva il diritto di apportare eventuali modifiche di parti o dettagli ritenuti necessari. Modelli e marchi depositati.

*Viganò has the right to change at any time the parts or details if necessary.
Registered models and trademarks.*

Viganò & C. srl

Via Barzagli, 5
20843 Verano Brianza
MB | Italy

tel. +39 0362 903531

tel. +39 0362 902603

fax +39 0362 990197

info@viganoffice.it

www.viganoffice.it



Viganò & C. srl

Via Barzagli, 5
20843 Verano Brianza
MB | Italy

tel. +39 0362 903531
tel. +39 0362 902603
fax +39 0362 990197

info@viganoffice.it
www.viganoffice.it